

Nov. 2008



SERVICE MANUAL ADDENDUM

IC-E2820

CONTENTS

REPLACEMENT PAGE	5-1
PARTS LIST	1
BOARD LAYOUTS	15
VOLTAGE DIAGRAM	17

SECTION 5 ADJUSTMENT PROCEDURE

5-1 PREPARATION

REQUIRED TEST EQUIPMENTS

When adjusting the transceiver, following test equipments and JIG cable (modified 8-pin modular jack; see the illust below) are required.

EQUIPMENT	GRADE AND RANGE	EQUIPMENT	GRADE AND RANGE
DC power supply	Output voltage : 13.8 V DC Current capacity : More than 20 A	Audio generator	Frequency range : 300–3000 Hz Output level : 1–500 mV
RF power meter (terminated type)	Measuring range : 1–100 W Frequency range : 100–600 MHz Impedance : 50 Ω SWR : Less than 1.2 : 1	Standard signal generator (SSG)	Frequency range : 0.1–1 GHz Output level : 0.1 μV to 32 mV (–127 to –17 dBm)
Frequency counter	Frequency range : 0.1–600 MHz Frequency accuracy: ±1 ppm or better Sensitivity : 100 mV or better	AC millivoltmeter	Measuring range : 10 mV to 10 V
		Terminator	Impedance : 50 Ω Capacity : More than 100 W
Modulation Analyzer	Frequency range : 30–600 MHz Measuring range : DC to ±10 kHz	Attenuator	Power attenuation : 40 dB Capacity : More than 100 W

JIG CABLE

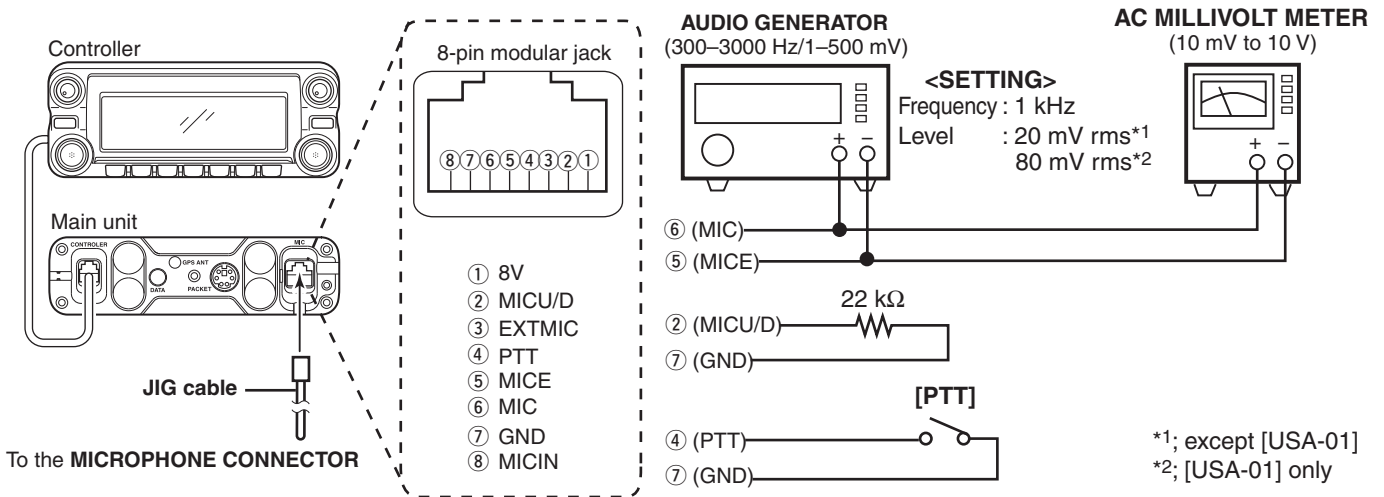

ENTERING ADJUSTMENT MODE

- Connect the JIG cable to the **MICROPHONE CONNECTOR** (see the illust above).
- Push and hold the both of **[MAIN•BAND]** keys, then turn power ON.

KEY ASSIGNMENTS IN THE ADJUSTMENT MODE

Entering adjustment mode, the function display shows adjustment item and conditions as below.

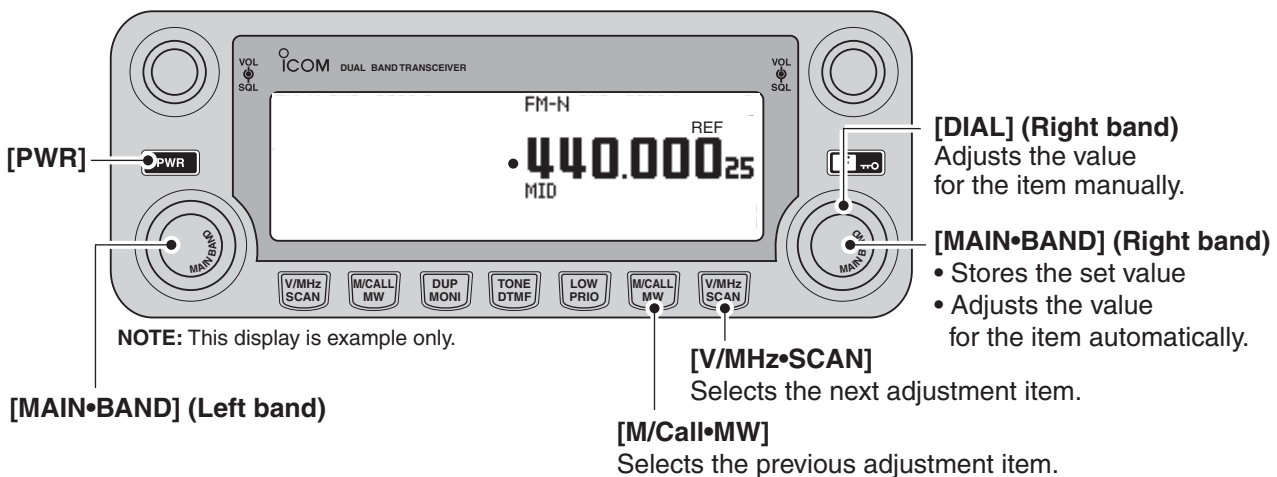

[CONTROL UNIT]

REF NO.	PARTS NO.	DESCRIPTION	M.	H/V LOCATION
C63	455000550	S.TAN TEESVA 1V 224M8R	B	72.7/36.9
C64	455000550	S.TAN TEESVA 1V 224M8R	B	72.6/39
C65	4030018860	S.CER ECJ0EB0J105K	B	96.8/26.2
C66	4030018860	S.CER ECJ0EB0J105K	B	49.8/30.1
C67	4030016790	S.CER ECJ0EB1C103K	B	41.8/16.2
C68	4030016790	S.CER ECJ0EB1C103K	B	44.8/18.5
C69	4030016790	S.CER ECJ0EB1C103K	B	29.6/23.7
C70	4030017460	S.CER ECJ0EB1E102K	B	17.7/31.9
C71	4510008550	S.ELE EEE1HA010SR	B	104.8/18.3
C72	4510008550	S.ELE EEE1HA010SR	B	104.7/23.9
C74	4030016790	S.CER ECJ0EB1C103K	B	113.5/26.7
C86	4030016790	S.CER ECJ0EB1C103K	B	22.1/26
C87	4030016790	S.CER ECJ0EB1C103K	B	116.1/25.4
C95	4550006840	S.TAN TEESVA 1E 225M8R	B	52.3/24.5
C101	4550006840	S.TAN TEESVA 1E 225M8R	B	93/25.2
C102	4550006840	S.TAN TEESVA 1E 225M8R	B	88.3/25.2
C104	4030016790	S.CER ECJ0EB1C103K	B	118.1/21
C105	4030017460	S.CER ECJ0EB1E102K	B	33.4/19
C106	4030016930	S.CER ECJ0EB1A104K	B	76.2/28.3
C107	4030016930	S.CER ECJ0EB1A104K	B	62/14.5
C108	4030016790	S.CER ECJ0EB1C103K	B	60.9/28.5
C109	4030017660	S.CER ECJ0EC1H330J	B	61.4/8.3
C110	4030017660	S.CER ECJ0EC1H330J	B	61.4/9.2
C111	4550006840	S.TAN TEESVA 1E 225M8R	B	85.7/25.2
C113	4030017330	S.CER ECJ0EF1C104Z	B	63.4/41.5
C114	4030017330	S.CER ECJ0EF1C104Z	B	65.9/41.5
C115	4030017330	S.CER ECJ0EF1C104Z	B	68.4/41.5
C116	4030017330	S.CER ECJ0EF1C104Z	B	69.2/37.2
C117	4030017330	S.CER ECJ0EF1C104Z	B	62.5/37.8
C118	4030017330	S.CER ECJ0EF1C104Z	B	64.7/37.8
C119	4030017330	S.CER ECJ0EF1C104Z	B	68/37.8
C120	4030017330	S.CER ECJ0EF1C104Z	B	66/36.6
C121	4030017490	S.CER C1608 JB 1A 105K-T	B	59.5/44.4
C122	4030017490	S.CER C1608 JB 1A 105K-T	B	61.3/44.1
J3	6510025760	S.CON B5B-ZR-SM4-TF(LF)(SN)	B	119.6/29.1
J4	6510025760	S.CON B5B-ZR-SM4-TF(LF)(SN)	B	24.6/29.1
J5	6510025730	CON HJC0187-010024		
J7	6510025830	S.CON 04-6240-034-001-800/+	B	92.9/34.6
J8	6510025830	S.CON 04-6240-034-001-800/+	B	48.1/34.6
DS1	5030003040	LCD M6-0103TRM-5	T	33/6.7
DS21	5040002930	S.LED SML-512MW T86	T	137.1/30
DS22	5040002930	S.LED SML-512MW T86	T	137.1/23.4
DS23	5040002930	S.LED SML-512MW T86	T	59/6.7
DS24	5040002930	S.LED SML-512MW T86	T	72/6.7
DS25	5040002930	S.LED SML-512MW T86	T	46/6.7
DS26	5040002930	S.LED SML-512MW T86	T	85/6.7
DS27	5040002930	S.LED SML-512MW T86	T	98/6.7
DS28	5040002930	S.LED SML-512MW T86	T	111/6.7
DS29	5040002930	S.LED SML-512MW T86	T	34.8/48
DS31	5040003260	S.LED FAMG1211F-TR	T	47.2/48
DS32	5040003260	S.LED FAMG1211F-TR	T	59.6/48
DS33	5040003260	S.LED FAMG1211F-TR	T	72/48
DS34	5040003260	S.LED FAMG1211F-TR	T	84.4/48
DS35	5040003260	S.LED FAMG1211F-TR	T	96.8/48
DS36	5040003260	S.LED FAMG1211F-TR	T	109.2/48
DS37	5040003260	S.LED FAMG1211F-TR	T	6.9/23.4
DS38	5040002930	S.LED SML-512MW T86	T	6.9/30
DS39	5040002930	S.LED SML-512MW T86	T	
S5	2260001890	S.SWI SKQDPA	T	33/3.2
S6	2260001890	S.SWI SKQDPA	T	46/3.2
S7	2260001890	S.SWI SKQDPA	T	98/3.2
S8	2260001890	S.SWI SKQDPA	T	111/3.2
S10	2260001890	S.SWI SKQDPA	T	137.1/26.7
S11	2260001890	S.SWI SKQDPA	T	59/3.2
S12	2260001890	S.SWI SKQDPA	T	72/3.2
S13	2260001890	S.SWI SKQDPA	T	85/3.2
S14	2260001890	S.SWI SKQDPA	T	6.9/26.7
S15	2250000570	ENC SW-169 (EC09E1524405)		
S16	2250000570	ENC SW-169 (EC09E1524405)		
EP9	6910012350	S.BEA MMZ1608Y 102BT	B	16/17.3
EP10	6910012350	S.BEA MMZ1608Y 102BT	B	15.3/26.6
EP11	6910012350	S.BEA MMZ1608Y 102BT	B	15.3/29

[VR1 UNIT]

REF NO.	PARTS NO.	DESCRIPTION	M.	H/V LOCATION
R1	7210003250	VAR RV-320 (RK097221005H)		
W1	8900016030	CAB OPC-1666 <TJM>		

[VR2 UNIT]

REF NO.	PARTS NO.	DESCRIPTION	M.	H/V LOCATION
R1	7210003250	VAR RV-320 (RK097221005H)		
W1	8900016030	CAB OPC-1666 <TJM>		

M.=Mounted side (T: Mounted on the Top side, B: Mounted on the Bottom side)
S.=Surface mount

[MAIN UNIT]

REF NO.	PARTS NO.	DESCRIPTION	M.	H/V LOCATION
C950	4030017400	S.CER ECJ0EC1H220J	T	89.7/49.1
C951	4030018890	S.CER ECJ0EB0J224K	T	76/47.7
C952	4030017570	S.CER ECJ0EC1H040B	T	36.4/137.1
C953	4030017360	S.CER ECJ0EC1H030B	T	37.7/136.7
C954	4510009010	S.ELE EEE1AA221P	T	13.2/36.6
C957	4030016950	S.CER ECJ0EB1A473K	T	110.9/120
RL1	6330001560	S.REL ATQ206SA	T	27.3/119.6
RL2	6330001560	S.REL ATQ206SA	T	64.7/122.9
RL3	6330001560	S.REL ATQ206SA	T	24.7/144.8
J1	6510014961	S.CON B2B-ZR-SM4-TF(LF)(SN)	T	48.3/136.1
J2	6510023110	CON 3008L-8P8C <KIN>		
J3	6510025950	CON PCB-606(6P6C) BLACK <BSUN>		
J4	6510023161	CON DN-508B-6-L <KOU>		
J5	6450001430	CON HSJ1462-01-010		
J6	6510021970	S.CON AXN330C130P	B	123.5/35.9
J7	6510014961	S.CON B2B-ZR-SM4-TF(LF)(SN)	B	101/108.4
J8	6510025940	CON PJ-3047S <XIN>		
J9	6450001440	CON HSJ1403-01-010		
J10	6510025970	S.CON 41-002AA-R <MRF>	T	94.8/112.6
J11	6510025970	S.CON 41-002AA-R <MRF>	T	39.7/123.2
J22	6510025970	S.CON 41-002AA-R <MRF>	T	94.8/117
J23	6510025970	S.CON 41-002AA-R <MRF>	T	36.5/119.6
J24	6510016381	S.CON 52465-1071	T	126.3/67.5
W1	8900016070	CAB OPC-1669(CA41410113000080A)		
W2	8900016070	CAB OPC-1669(CA41410113000080A)		
W5	7120000470	JUM ERDS2T0		
W6	7120000470	JUM ERDS2T0		
W7	8900016020	CAB OPC-1671 <TJM>		
EP1	6910014690	S.BEA MPZ1608S221A-T	T	49.3/117.4
EP2	6910014690	S.BEA MPZ1608S221A-T	T	51.1/133.4
EP3	6910012350	S.BEA MMZ1608Y 102BT	B	44.3/88.7
EP4	6910012350	S.BEA MMZ1608Y 102BT	B	39.4/88.2
EP5	6910012350	S.BEA MMZ1608Y 102BT	T	8.9/17.2
EP6	6910018460	S.BEA MMZ1005Y102C-T	T	8/22.9
EP7	6910018460	S.BEA MMZ1005Y102C-T	T	10.9/17.7
EP8	6910018460	S.BEA MMZ1005Y102C-T	T	12.4/25
EP9	6910018460	S.BEA MMZ1005Y102C-T	T	16/25.3
EP10	6910018460	S.BEA MMZ1005Y102C-T	T	13.9/25.3
EP11	6910012350	S.BEA MMZ1608Y 102BT	T	15/17.2
EP12	6910018460	S.BEA MMZ1005Y102C-T	T	18.2/21.6
EP13	6910012350	S.BEA MMZ1608Y 102BT	T	125.9/19.6
EP14	6910012350	S.BEA MMZ1608Y 102BT	T	120.2/21.7
EP16	6910018460	S.BEA MMZ1005Y102C-T	T	122.9/22.5
EP18	6910018460	S.BEA MMZ1005Y102C-T	B	121.6/94
EP19	6910018460	S.BEA MMZ1005Y102C-T	B	123.7/81.5
EP20	6910018460	S.BEA MMZ1005Y102C-T	B	125.7/80.6
EP23	6910018460	S.BEA MMZ1005Y102C-T	T	12.9/28.9
EP24	6910018460	S.BEA MMZ1005Y102C-T	T	57.1/9.6
EP25	6910018460	S.BEA MMZ1005Y102C-T	B	127.7/32.3
EP26	6910018460	S.BEA MMZ1005Y102C-T	B	119.2/41.6
EP27	6910018460	S.BEA MMZ1005Y102C-T	B	119.2/40.7
EP29	6910018460	S.BEA MMZ1005Y102C-T	B	119.2/39.4
EP30	6910018460	S.BEA MMZ1005Y102C-T	B	127.7/39.5
EP31	6910018460	S.BEA MMZ1005Y102C-T	T	89.4/9.8
EP32	6910018460	S.BEA MMZ1005Y102C-T	T	89/4.9
EP33	6910018460	S.BEA MMZ1005Y102C-T	B	127.7/42.2
EP34	6910018460	S.BEA MMZ1005Y102C-T	B	127.7/41.3
EP35	6910018460	S.BEA MMZ1005Y102C-T	B	127.7/31.4
EP36	6910018460	S.BEA MMZ1005Y102C-T	B	127.7/40.4
EP37	6910018460	S.BEA MMZ1005Y102C-T	T	89.5/1.7
EP38	6910018460	S.BEA MMZ1005Y102C-T	B	127.7/38.6
EP39	6910018460	S.BEA MMZ1005Y102C-T	B	127.7/37.7
EP40	6910018460	S.BEA MMZ1005Y102C-T	B	127.7/36.8
EP41	6910018460	S.BEA MMZ1005Y102C-T	B	127.7/34.1
EP42	6910018460	S.BEA MMZ1005Y102C-T	B	127.7/35.9
EP43	6910018460	S.BEA MMZ1005Y102C-T	B	127.7/33.2
EP47	6910018460	S.BEA MMZ1005Y102C-T	T	45.7/57.9
EP48	6910018460	S.BEA MMZ1005Y102C-T	T	91/61.3
EP49	6910014690	S.BEA MPZ1608S221A-T	T	121.3/152.3
EP50	6910014690	S.BEA MPZ1608S221A-T	T	109.4/155.1
EP51	6910018460	S.BEA MMZ1005Y102C-T	T	119.3/144.2
EP52	6910014690	S.BEA MPZ1608S221A-T	T	128.6/143.6
EP53	6910014690	S.BEA MPZ1608S221A-T	T	126.3/144.3
EP54	6910014690	S.BEA MPZ1608S221A-T	T	113.9/138.9
EP55	6910014690	S.BEA MPZ1608S221A-T	T	108.6/147.8
EP56	6910018460	S.BEA MMZ1005Y102C-T	B	119.3/38.5
EP57	6910018460	S.BEA MMZ1005Y102C-T	B	119.3/37.6
EP58	6910018460	S.BEA MMZ1005Y102C-T	B	119.3/36.7
EP59	6910014690	S.BEA MPZ1608S221A-T	B	117.2/36.3
EP60	6910014690	S.BEA MPZ1608S221A-T	B	117.2/35.1
EP61	6910018460	S.BEA MMZ1005Y102C-T	B	119.3/34.3
EP62	6910018460	S.BEA MMZ1005Y102C-T	B	119.3/33.4
EP63	6910018460	S.BEA MMZ1005Y102C-T	B	119.3/32.5
EP64	6910018460	S.BEA MMZ1005Y102C-T	B	119.3/31.6
EP66	6910018460	S.BEA MMZ1005Y102C-T	B	127.7/35
EP68	6910018460	S.BEA MMZ1005Y102C-T	B	41.6/14.3
EP69	6910018460	S.BEA MMZ1005Y102C-T	T	52.6/10.4
EP70	6910018460	S.BEA MMZ1005Y102C-T	T	45/8
EP71	6910012350	S.BEA MMZ1608Y 102BT	T	47.5/130.7

[MAIN UNIT]

REF NO.	PARTS NO.	DESCRIPTION	M.	H/V LOCATION
MP2	8510018150	S.CAS 2969 B-VCO CASE	T	78.7/41.9
MP3	8510014940	S.CAS 2601 VCO CASE Y641	T	83.2/63
MP4	8510018150	S.CAS 2969 B-VCO CASE	T	34.1/41.9
MP5	8510014940	S.CAS 2601 VCO CASE Y641	T	38.6/62.9
MP6	8510016470	S.CAS 2775 VCO CASE	B	25.9/46.7
MP7	8510016470	S.CAS 2775 VCO CASE	B	70.4/46.8
MP8	8510018140	S.CAS 2969 S-VCO CASE	T	68.2/86.5
MP9	8510018140	S.CAS 2969 S-VCO CASE	T	18.8/86.8

M.=Mounted side (T: Mounted on the Top side, B: Mounted on the Bottom side)
S.=Surface mount

BOARD LAYOUTS

The combination of this side and the bottom side shows the board layout in the same configuration as the actual P.C.Board.

• MAIN UNIT (TOP VIEW)

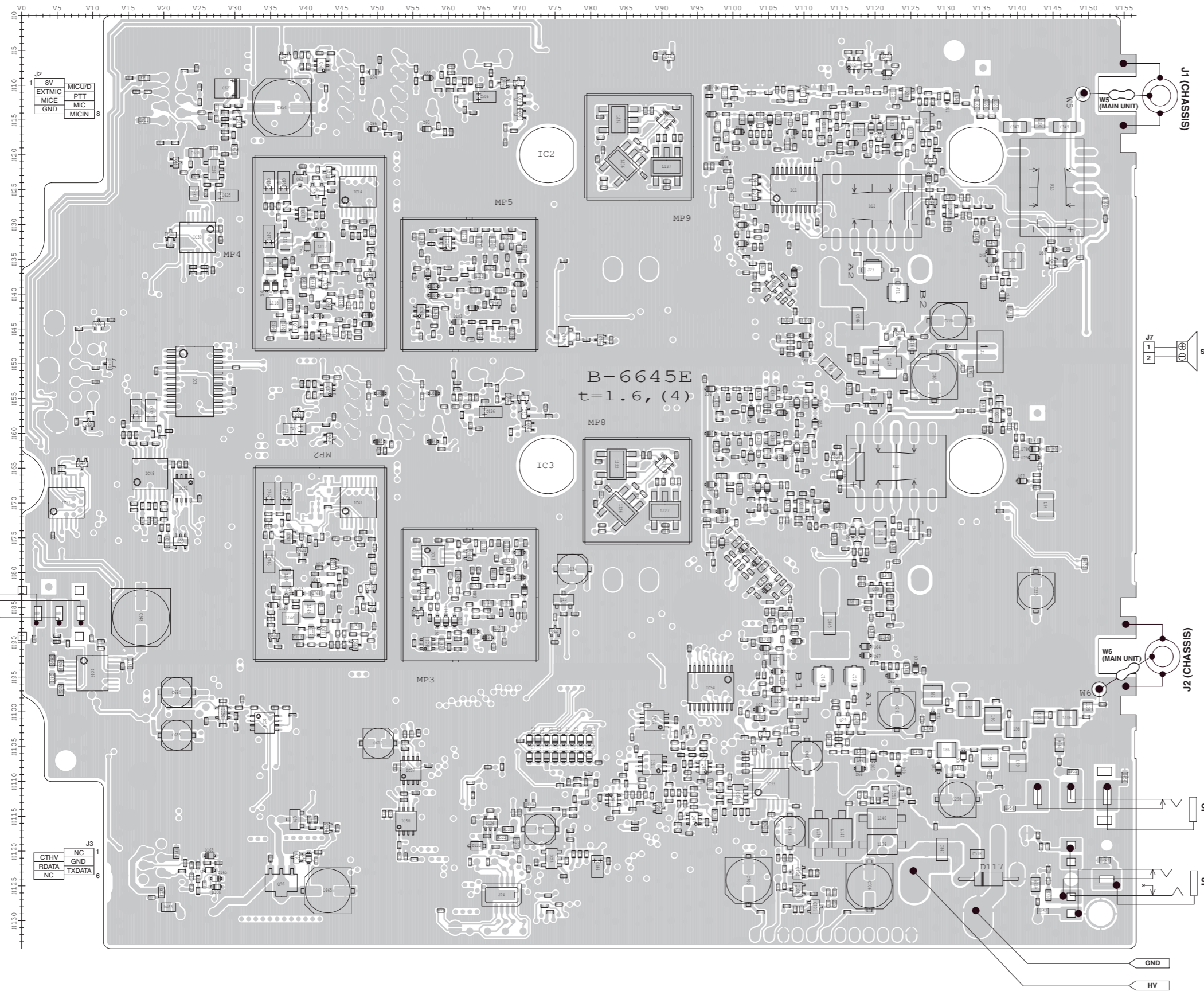

• HM-133 (TOP VIEW)

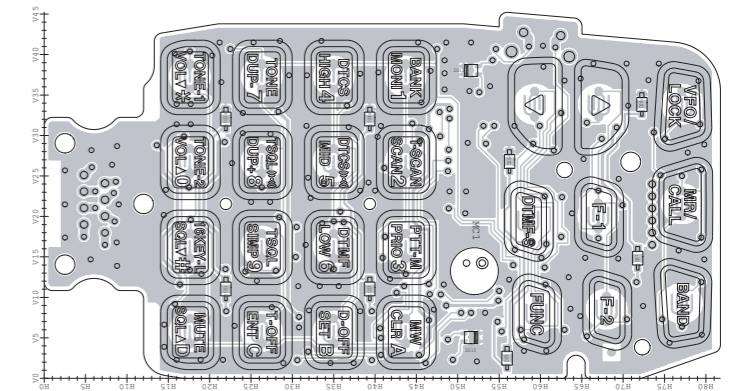

• VR1 UNIT (TOP VIEW)

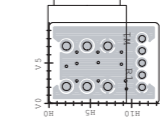

• CONTROL UNIT (TOP VIEW)

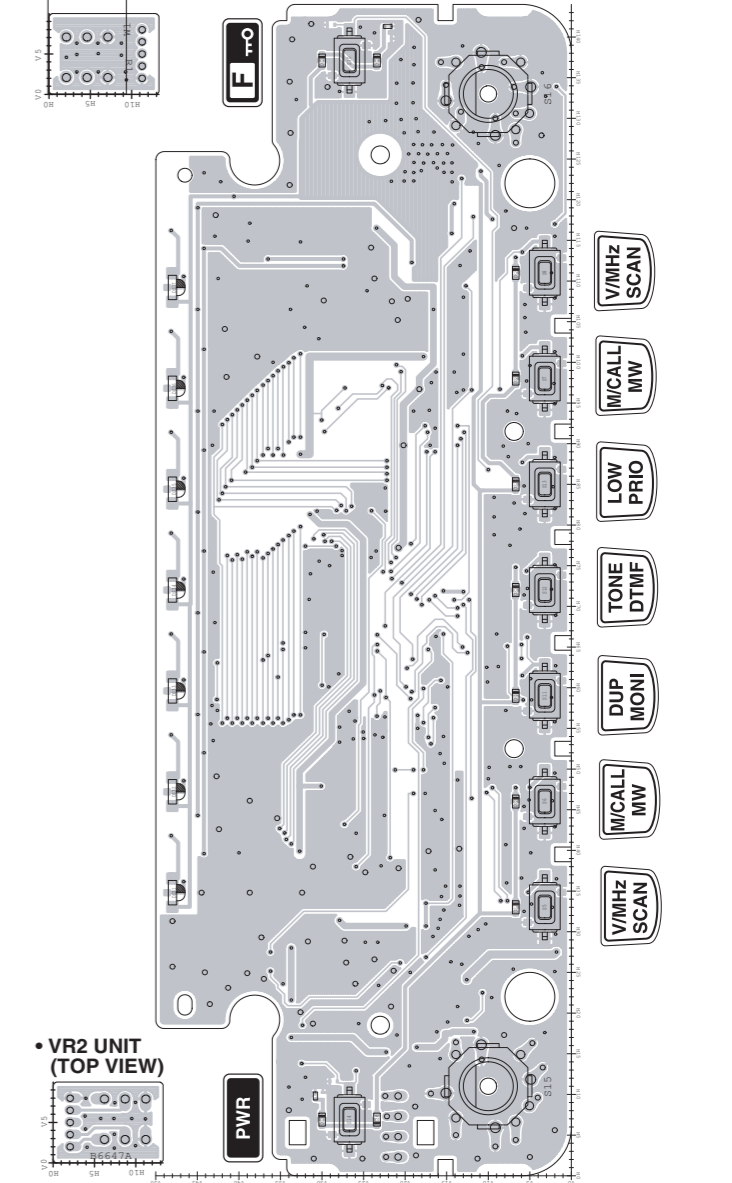

• VR2 UNIT (TOP VIEW)

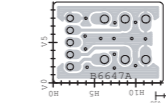

The combination of this side and the bottom side shows the board layout in the same configuration as the actual P.C.Board.

• HM-133 (BOTTOM VIEW)

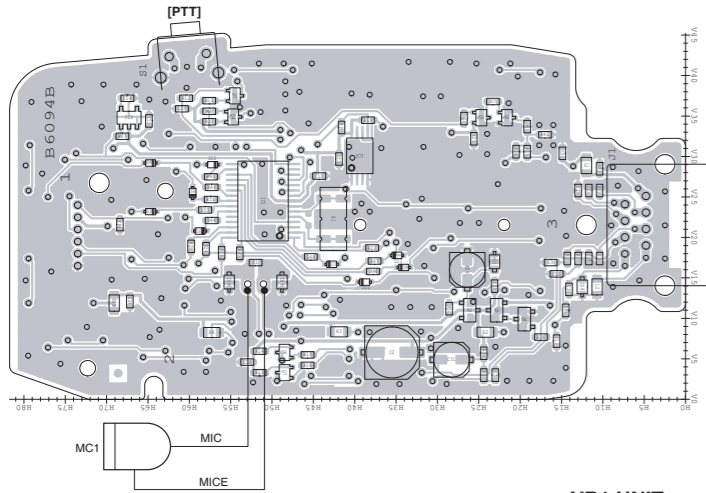

• MAIN UNIT (BOTTOM VIEW)

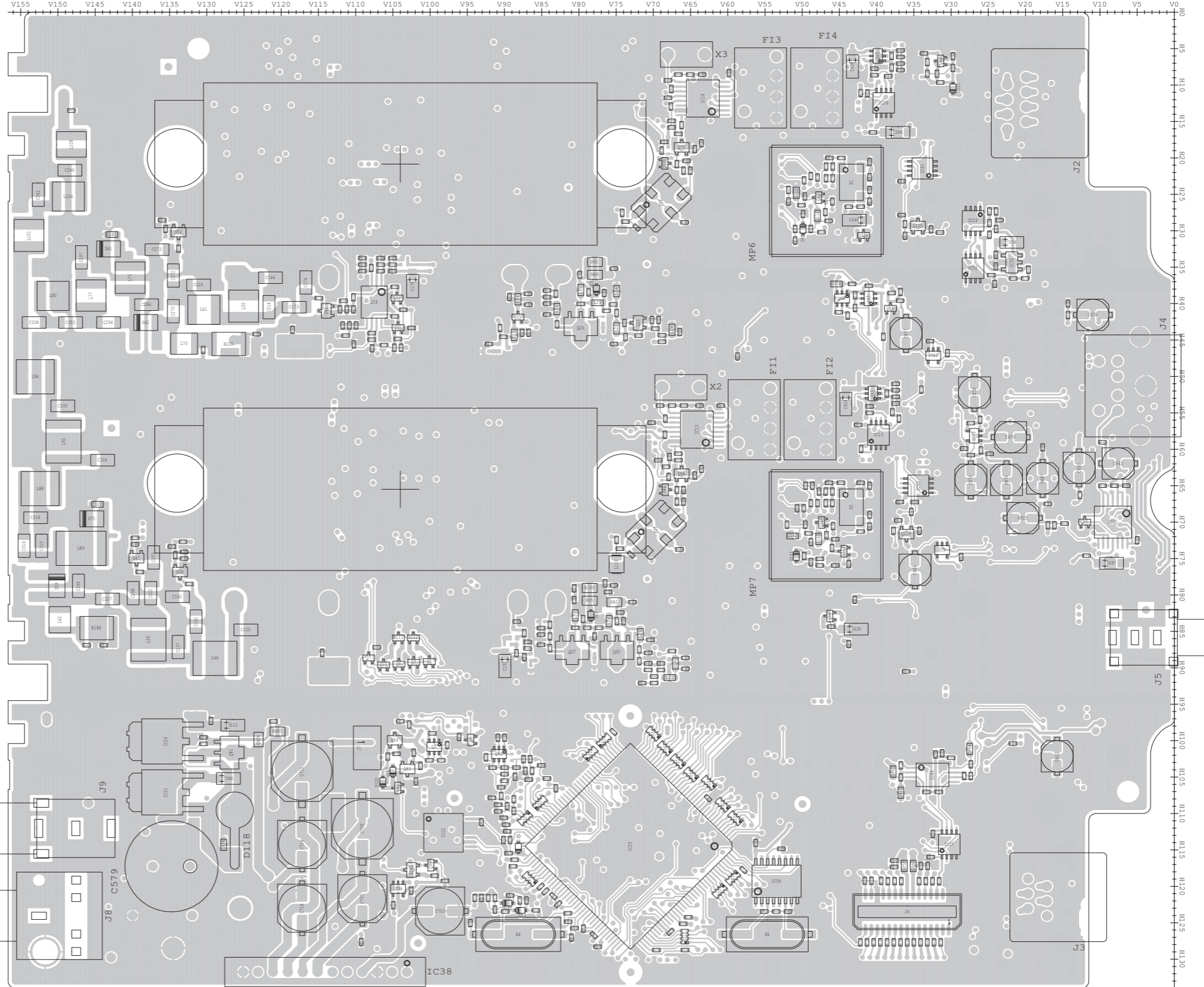

30	GND	NC
31	NC	NC
32	BTONE	AMBERTXD
33	BTOUT	AMBERTXD
34	AF	DVC
35	DMOD	AOO
36	OSV	TKOK
37	OP-HV	TKOK
38	AMBERTN	TKOK
39	AMBERTS	DCB
40	AMBERTK	CRUSV
41	GND	GPSRST
42	GPSRST0	GPSRST
43	GPSRST00	GPSRST
44	GPSRST000	GPSRST
45	GPSRST0000	GPSRST

• CONTROL UNIT (BOTTOM VIEW)

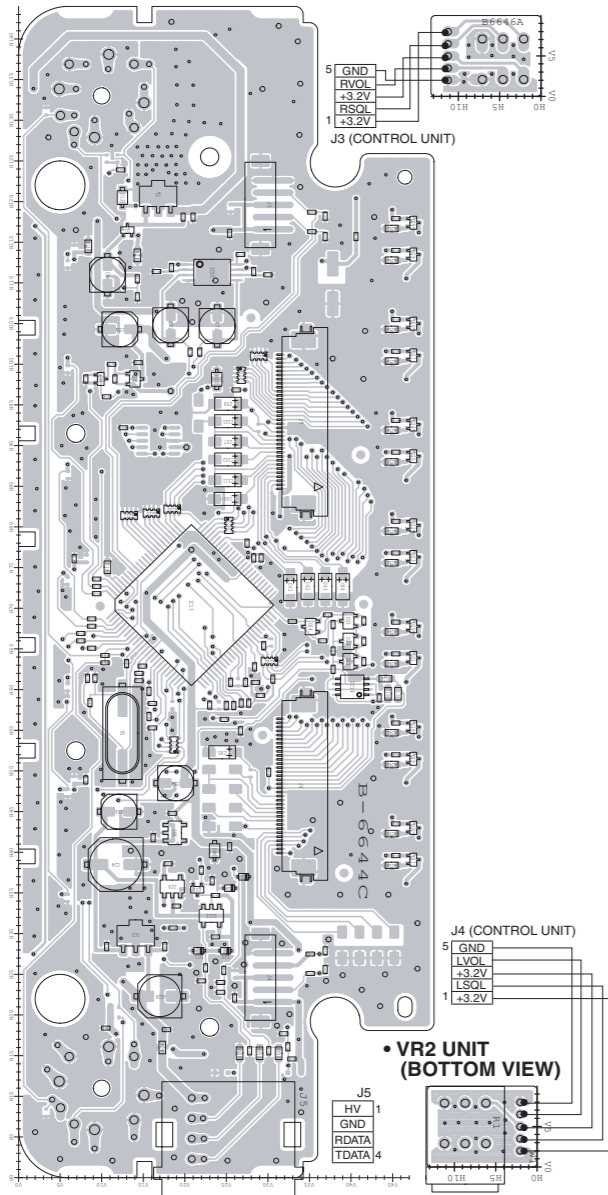

• VR1 UNIT (BOTTOM VIEW)

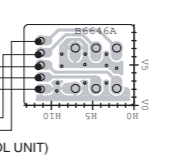

• VR2 UNIT (BOTTOM VIEW)

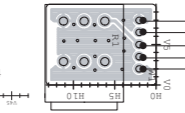

VOLTAGE DIAGRAM

10-1 CONTROL UNIT

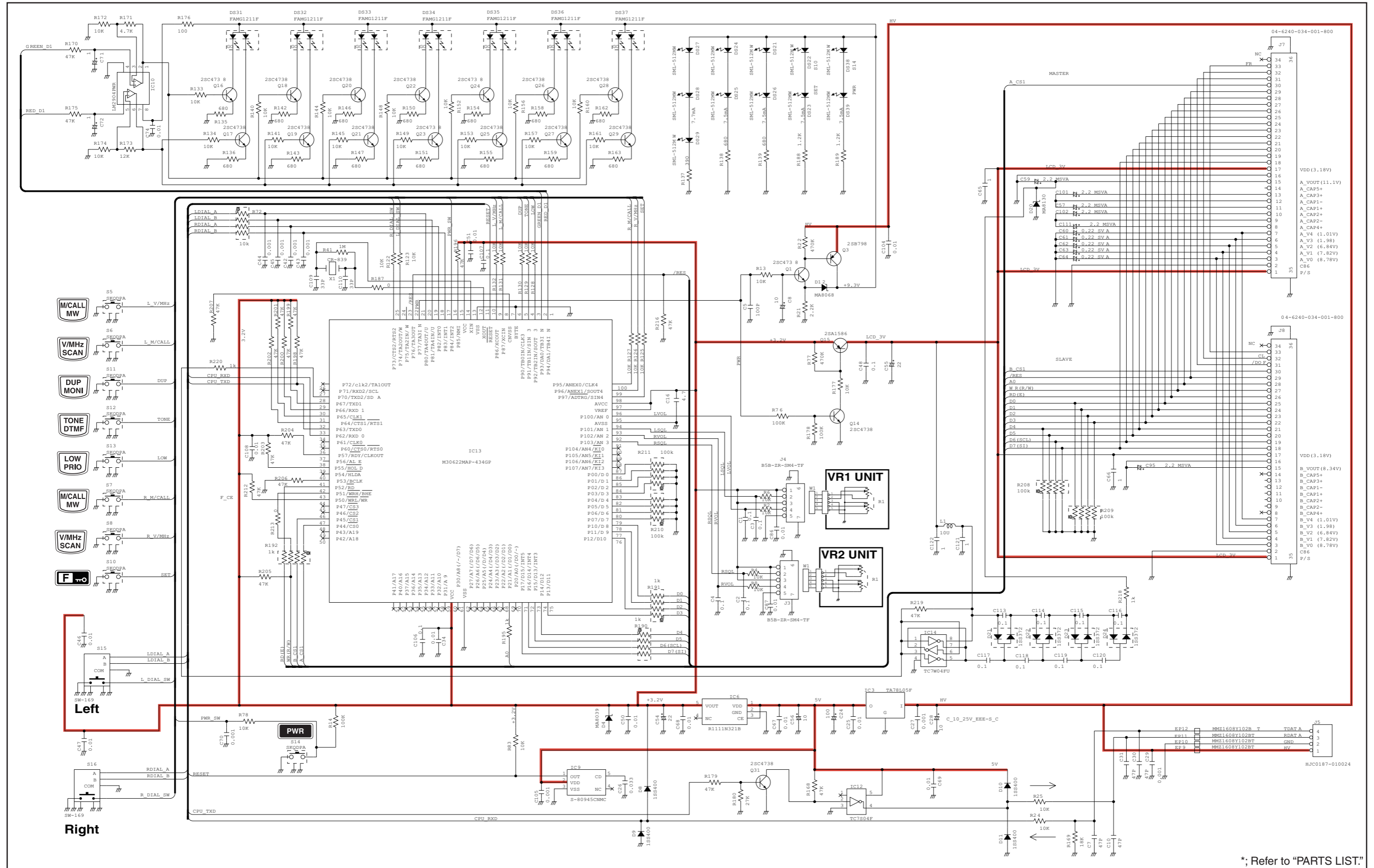

*; Refer to "PARTS LIST."

10-2 MAIN UNIT (1)

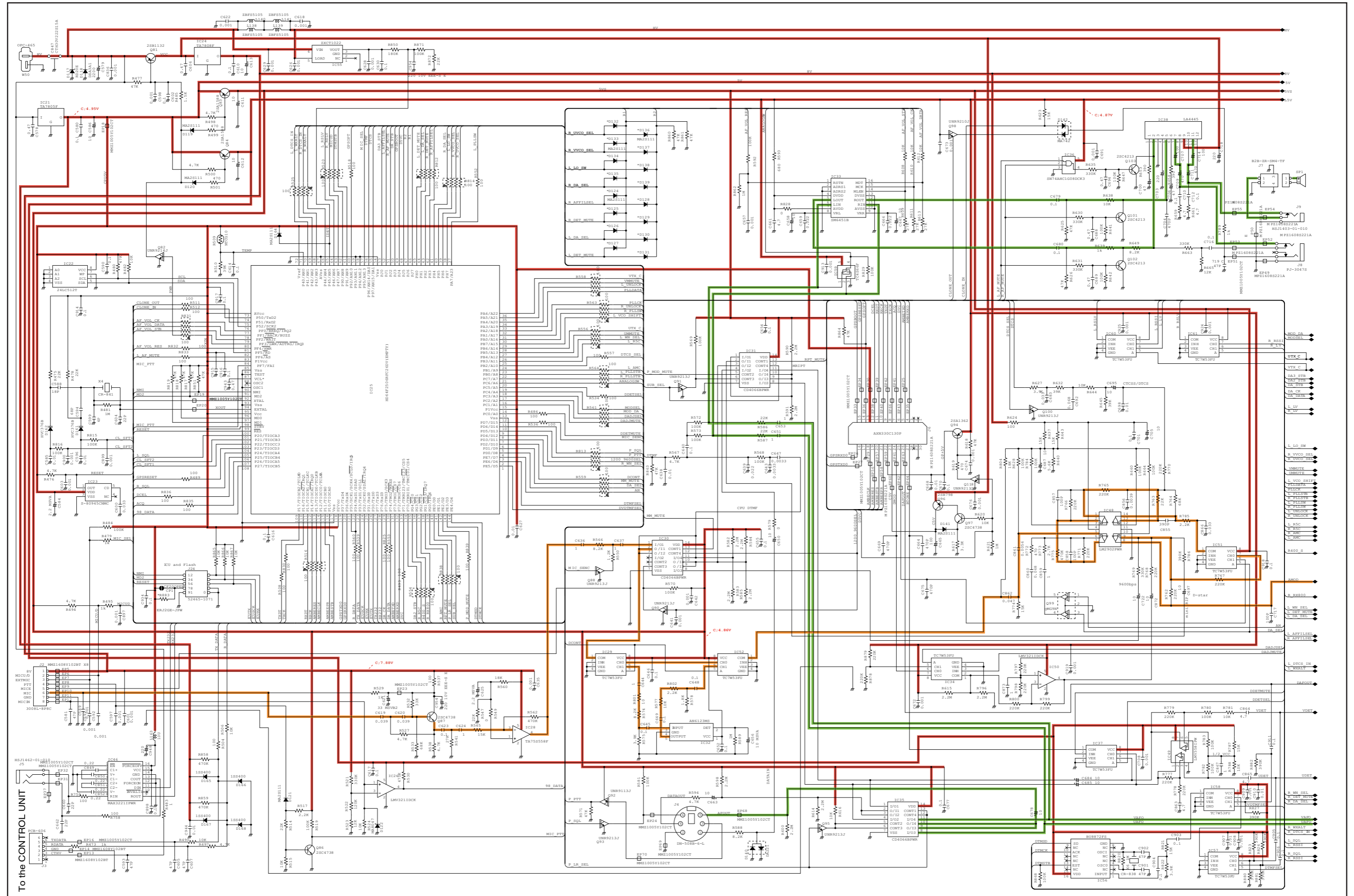

*; Refer to "PARTS LIST"

MAIN UNIT (2)

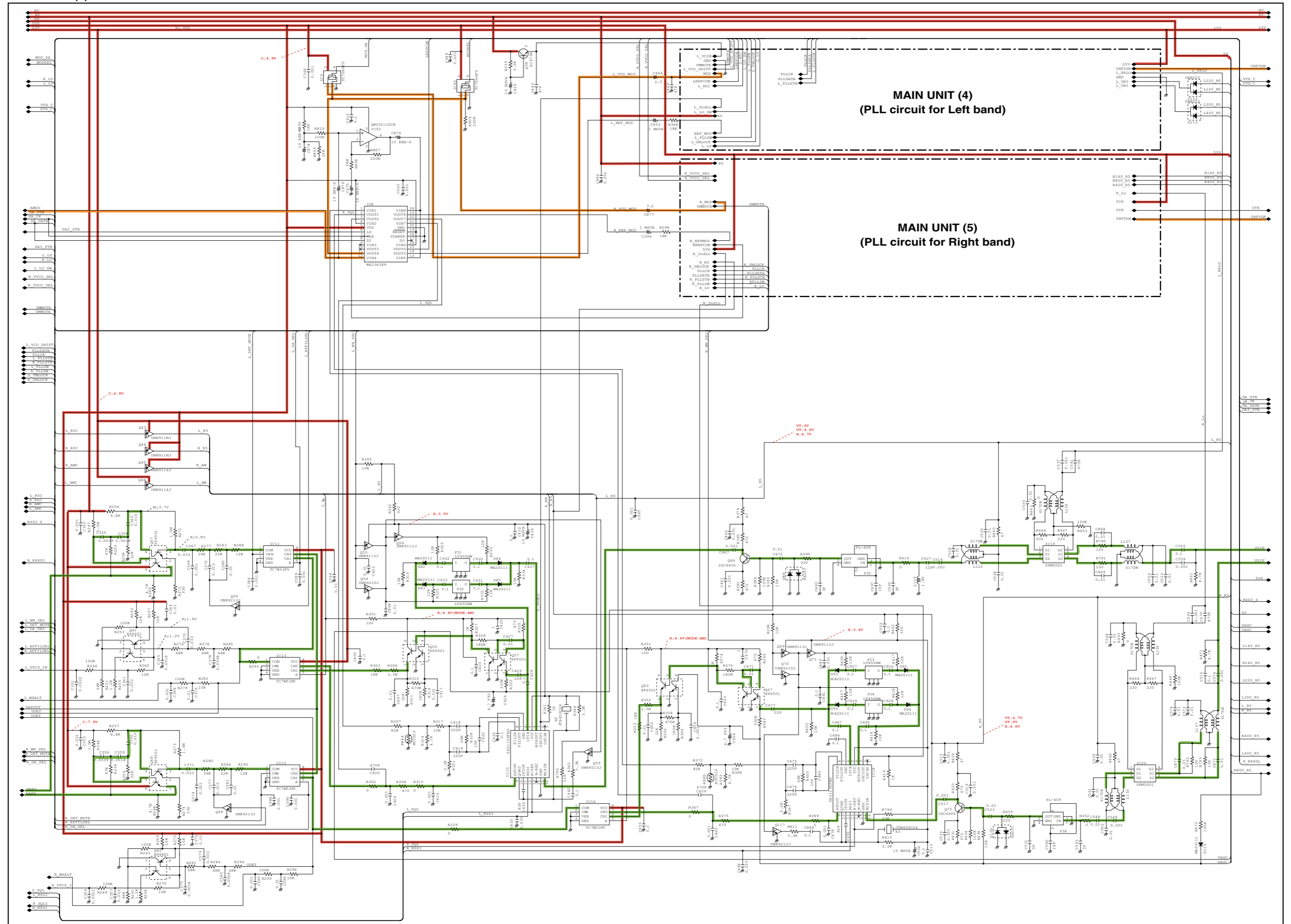

MAIN UNIT (3)

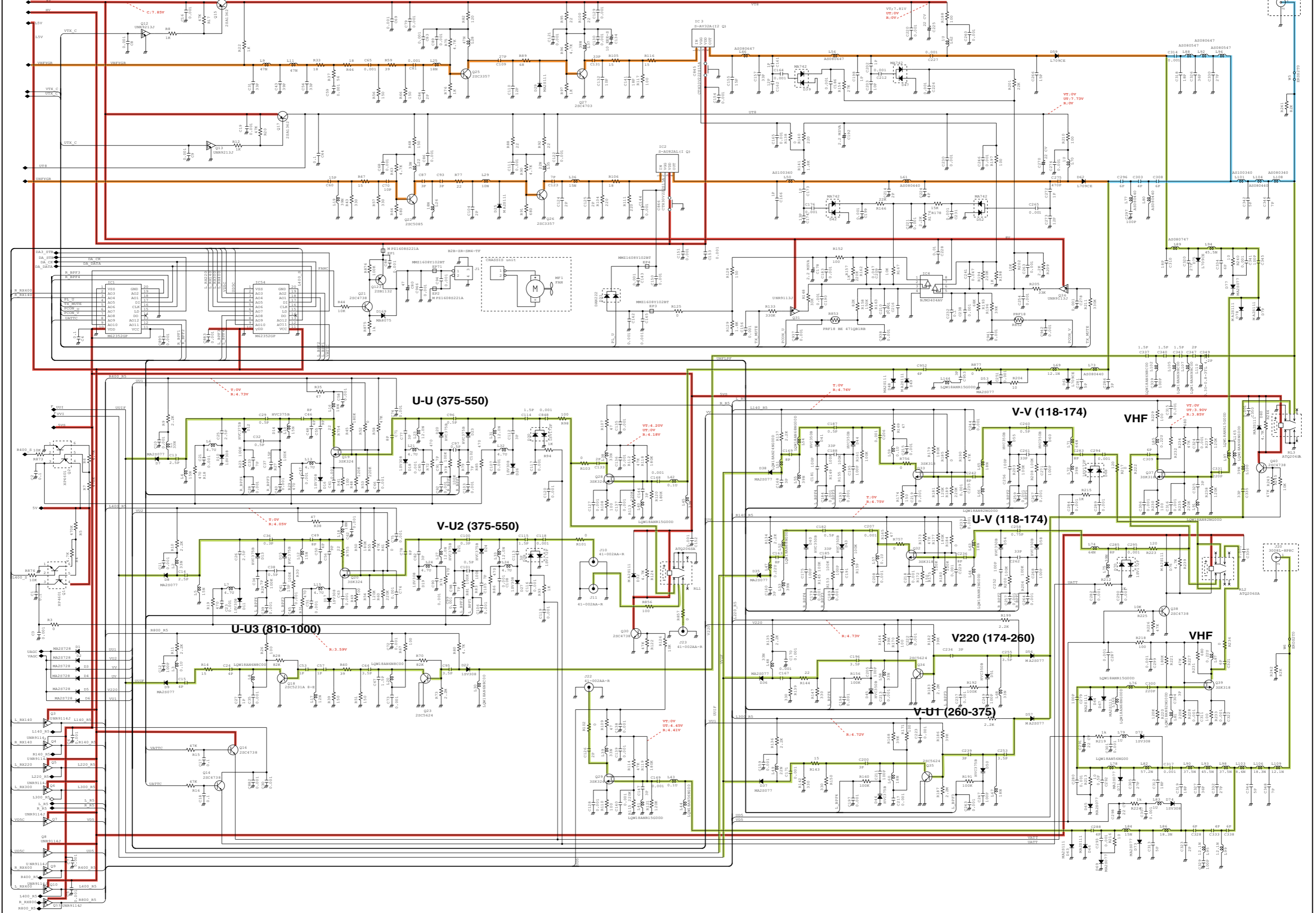

MAIN UNIT (4)

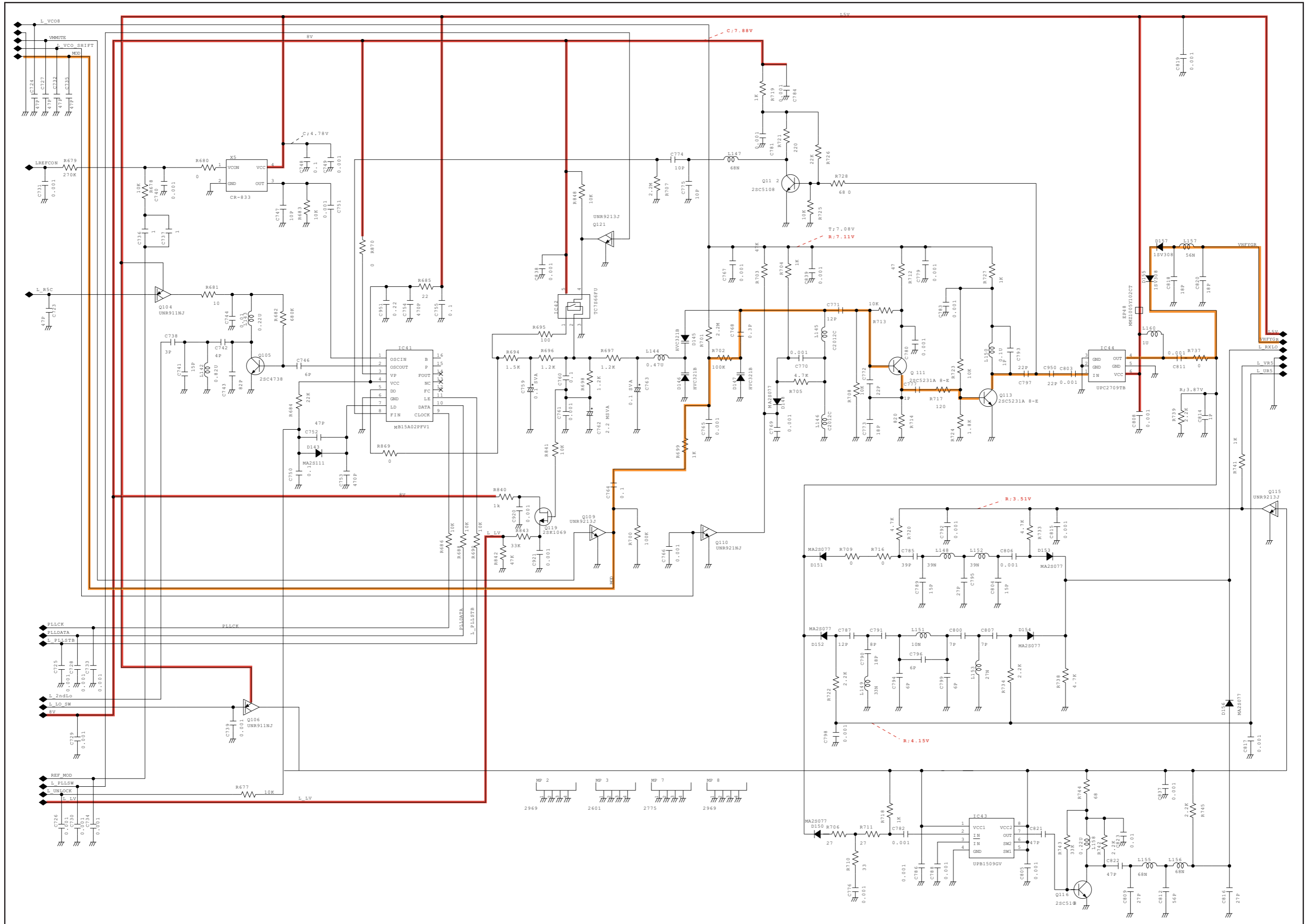

MAIN UNIT (5)

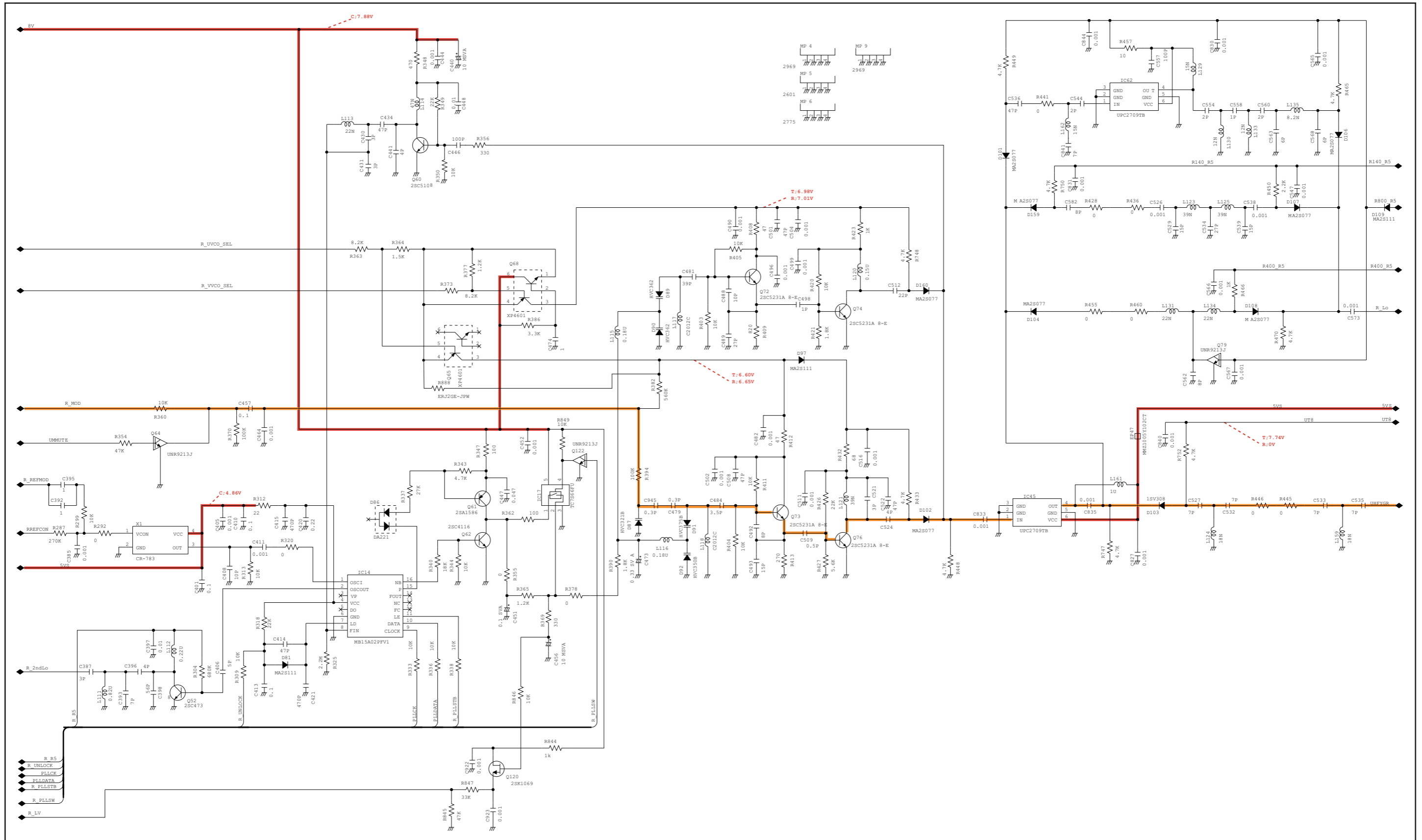



SERVICE MANUAL

DUAL BAND FM TRANSCEIVER

IC-E2820

S-14326XZ-C1
Apr. 2007

Icom Inc.

INTRODUCTION

This service manual describes the latest service information for the **IC-E2820** DUAL BAND FM TRANSCEIVER at the time of publication.

MODEL	VERSION
IC-E2820	EUR-01
	EUR-02

To upgrade quality, any electrical or mechanical parts and internal circuits are subject to change without notice or obligation.

CAUTION

NEVER connect the transceiver to an AC outlet or to a DC power supply that uses more than 15 V. This will ruin the transceiver.

DO NOT expose the transceiver to rain, snow or any liquids.

DO NOT reverse the polarities of the power supply when connecting the transceiver.

DO NOT apply an RF signal of more than 20 dBm (100 mW) to the antenna connectors. This could damage the transceiver's front end.



ORDERING PARTS

Be sure to include the following four points when ordering replacement parts:

1. 10-digit order numbers
2. Component part number and name
3. Equipment model name and unit name
4. Quantity required

<SAMPLE ORDER>

1110003491	S.IC	TA31136FNG	IC-E2820	MAIN UNIT	5 pieces
8820001210	Screw	2438 screw	IC-E2820	Top cover	10 pieces

Addresses are provided on the inside back cover for your convenience.

REPAIR NOTES

1. Make sure a problem is internal before disassembling the transceiver.
2. **DO NOT** open the transceiver until the transceiver is disconnected from its power source.
3. **DO NOT** force any of the variable components. Turn them slowly and smoothly.
4. **DO NOT** short any circuits or electronic parts. An insulated tuning tool **MUST** be used for all adjustments.
5. **DO NOT** keep power ON for a long time when the transceiver is defective.
6. **DO NOT** transmit power into a signal generator or a sweep generator.
7. **ALWAYS** connect a 50 dB to 60 dB attenuator between the transceiver and a Modulation Analyzer or spectrum analyzer when using such test equipment.
8. **READ** the instructions of test equipment thoroughly before connecting equipment to the transceiver.

CONTENTS

SECTION 1 SPECIFICATIONS

SECTION 2 INSIDE VIEWS

SECTION 3 DISASSEMBLY INSTRUCTIONS

SECTION 4 CIRCUIT DESCRIPITON

4-1	RECEIVER CIRCUITS.....	4-1
4-2	TRANSMITTER CIRCUITS	4-4
4-3	FREQUENCY SYNTHESIZER	4-6
4-4	POWER SUPPLY CIRCUITS.....	4-8
4-5	PORT ALLOCATIONS	4-9

SECTION 5 ADJUSTMENT PROCEDURES

5-1	PREPARATION	5-1
5-2	FREQUENCY ADJUSTMENT	5-2
5-3	TRANSMIT ADJUSTMENT	5-3
5-4	RECEIVE ADJUSTMENT	5-4

SECTION 6 PARTS LIST

SECTION 7 MECHANICAL PARTS

SECTION 8 BOARD LAYOUTS

SECTION 9 BLOCK DIAGRAM

SECTION 10 VOLTAGE DIAGRAM

SECTION 11 HM-133

SECTION 12 UT-123 (Optional product)

GENERAL

- Frequency coverage : (unit: MHz)

Version	Left Band	Right Band
Europe1	Rx: 118–549.995 ^{*1, *2} Tx: 144–146, 430–440	Rx: 118–173.995 ^{*1} , 375–549.995 ^{*2} , 810–999.99 ^{*3} Tx: 144–146, 430–440
Europe2	Tx/Rx: 144–146, 430–440	

^{*1}Guaranteed: 144–146 MHz range only.; ^{*2}Guaranteed: 430–440 MHz; ^{*3}Not guaranteed

- Type of emission : FM, AM (Receive only),
DV (optional UT-123 is required)
- Number of memory channels : 522 (incl. 20 scan edges and 2 calls)
- Frequency resolution : 5, 6.25, 10, 12.5, 15, 20, 25, 30, 50 kHz
- Operating temperature range : –10°C to +60°C
- Frequency stability : ±2.5 ppm (–10°C to +60°C)
- Power supply requirement : 13.8 V DC ±15%
- Current drain (at 13.8 V DC: approx.):

Transmit	at 50 W	13 A
Receive	standby	1.2 A
(simultaneous receive)	max. audio	1.8 A
- Antenna connector : SO-239 (50 Ω)×2 (Tx/Rx and Diversity)
- Dimensions (proj. not included) :

Main Unit	150(W) × 40(H) × 187.7(D) mm
Remote controller	150(W) × 58(H) × 31.5(D) mm
- Weight (approx.) :

Main unit	1.5 kg
Remote controller	210 g (incl. separation cable)

TRANSMITTER

- Modulation system : Variable reactance frequency modulation
- Output power : 50/15/5 W (approx.)
- Max. frequency deviation : ±5.0 kHz (wide)
±2.5 kHz (narrow)
- Spurious emissions : Less than –60 dB
- Microphone connector : 8-pin modular (600 Ω)

RECEIVER

- Receive system : Double-conversion superheterodyne
- Intermediate frequencies :

Left band	1st: 38.85 MHz, 2nd: 450 kHz
Right band	1st: 46.35 MHz, 2nd: 450 kHz
- Sensitivity (amateur bands only):

FM (12 dB SINAD)	Less than 0.18 μV
DV (BER 1%) (optional UT-123 is required)	Less than 0.35 μV
- Squelch sensitivity[†] (threshold) : Less than 0.13 μV
- Selectivity[†] (typical) :

Wide	More than 10 kHz/6 dB Less than 30 kHz/60 dB
Narrow	More than 6 kHz/6 dB Less than 20 kHz/60 dB
DV (optional UT-123 is required)	More than 50 dB
- Spurious and image rejection[†] : More than 60 dB
^{*}More than 55 dB for UHF on left band.
- AF output power[†] (at 13.8 V DC) : More than 2.4 W at 10% distortion with an
8 Ω load
- Ext. speaker connectors : 3-conductor 3.5 (d) mm/8 Ω

[†]Guaranteed 144–146 MHz and 430–440 MHz ranges only.

All stated specifications are subject to change without notice or obligation.

• TOP VIEW

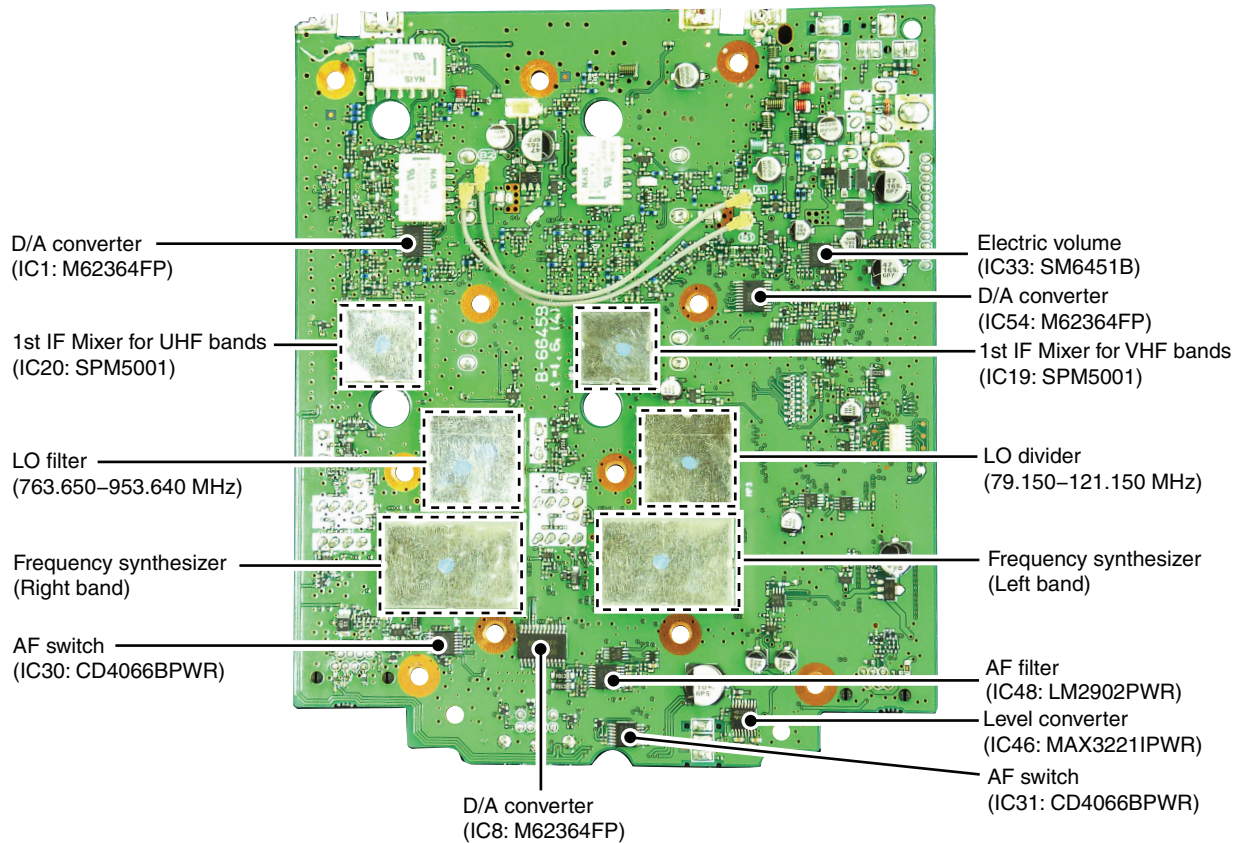

• BOTTOM VIEW

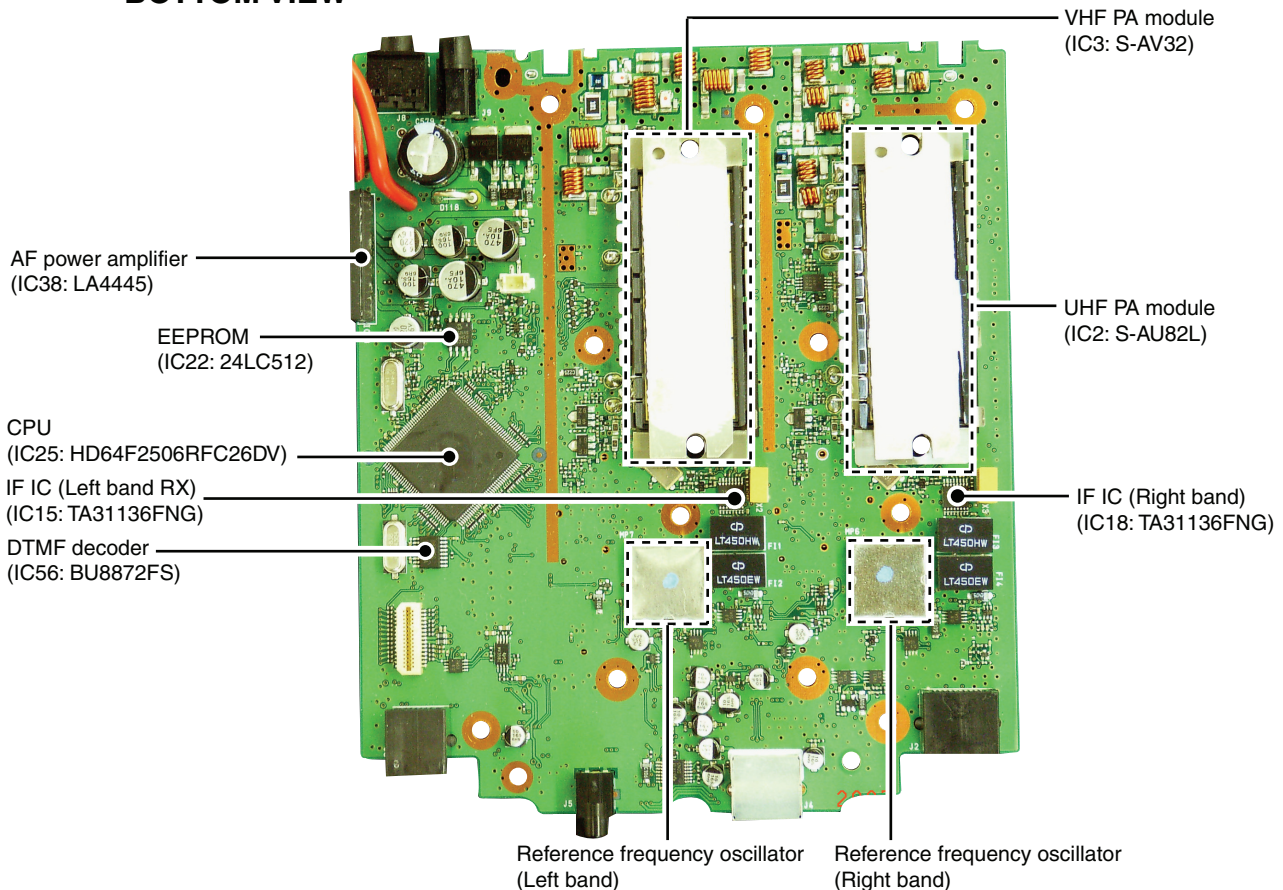

SECTION 3 DISASSEMBLY INSTRUCTION

1. Removing the top cover

① Unscrew 10 screws, then remove the top cover.

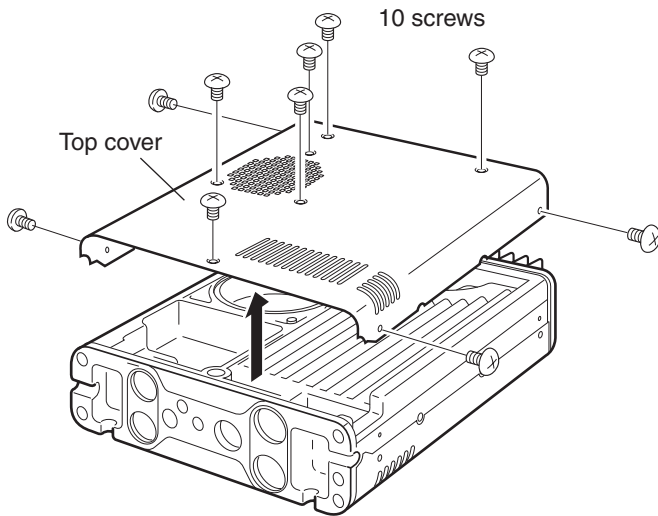

② Disconnect the speaker cable.

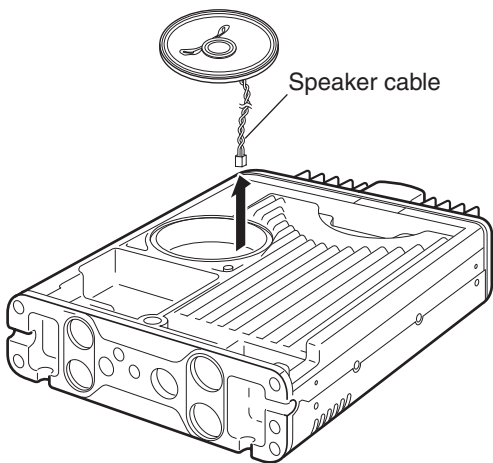

2. Removing the bottom cover

① Unscrew 7 screws, then remove the bottom cover.

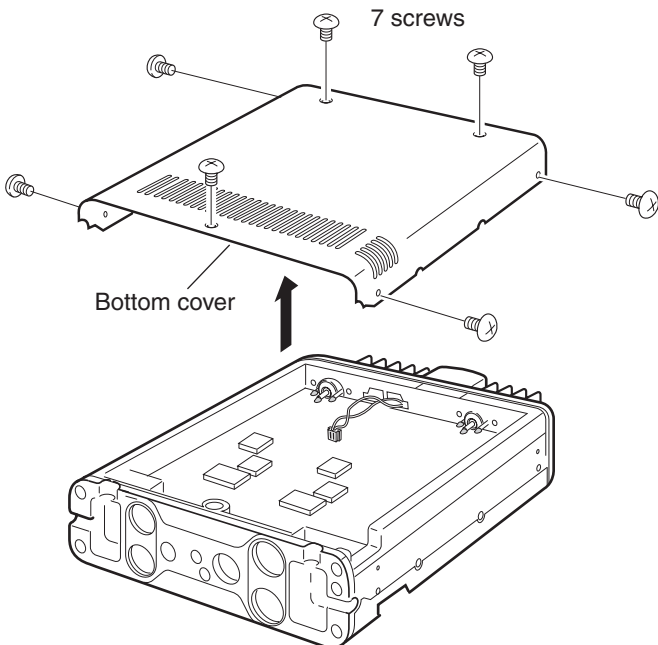

3. Removing the MAIN UNIT

① Unscrew 11 screws from the MAIN UNIT.

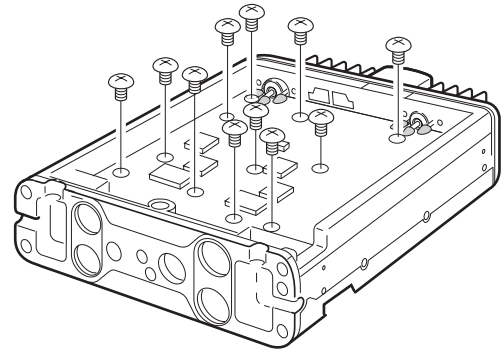

② Disconnect the cooling fan cable, and unsolder 6 points at the antenna connectors (grey colored).

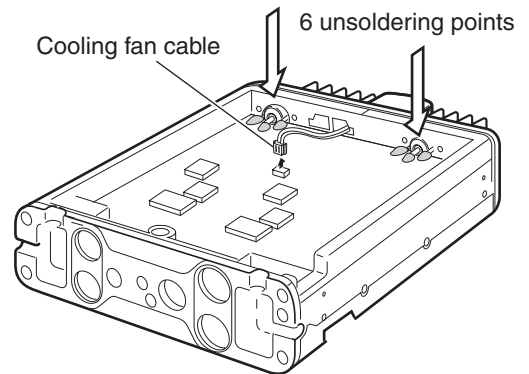

③ Remove the MAIN UNIT in the direction of the arrow.

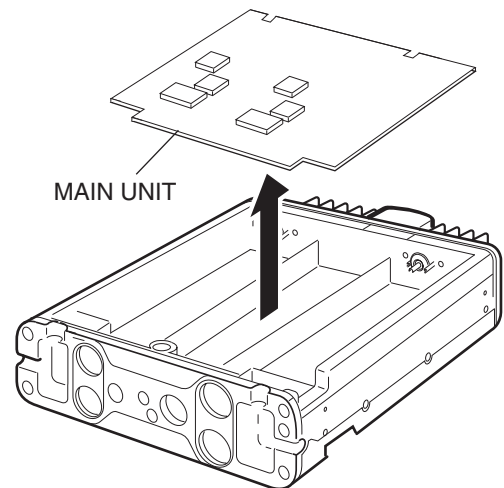

4-1 RECEIVER CIRCUITS

RF CIRCUITS

<Left band>

• 118–174 MHz

The received signals from the antenna connector ANT-1 (J1) are passed through two LPFs (L101, 104, 108, C342, 346; L88, 92, 96, C318, 326, 330), then applied to the RF amplifier (Q37) via TX/RX switch (D75). The amplified signals are passed through the RX switch (RL2), attenuator (D68) and tuned BPF (D55, 66), before being applied to another RF amplifier (Q33). The amplified signals are applied to the 1st mixer (IC19) via the another tuned BPF (D41, 44) and RX switch (D38).

While the diversity operation is activated, the received signals are also input from ANT-2 (J2). The received signals are passed through two LPFs (L103, 106, 109, C344, 348; L90, 93, 98, C319, 327, 348), antenna switch (D65, 72) and limiter (D64, 67), then applied to the RF amplifier (Q39).

The amplified signals are applied to the RX switch (RL2), and gone through the same process as the received signals from ANT-1 (J1).

• 174–260 MHz

The received signals from the antenna connector (J1) are passed through two RX switches (RL3 and D56) and the tuned BPF (D51), then applied to the RF amplifier (Q34). The amplified signals are passed through the BPF (D45), attenuator (R139, 144, 147) and RX switch (D36) before being applied to the 1st mixer (IC19).

• 260–375 MHz

The received signals from the antenna connector (J1) are passed through two RX switches (RL3 and D57) and the tuned BPF (D50), then applied to the RF amplifier (Q35).

The amplified signals are passed through the BPF (D465), attenuator (R142, 143, 150) and RX switch (D37) before being applied to the 1st mixer (IC19).

• 375–550 MHz

The received signals from the antenna connector (J1) are passed through the LPF (L101, 104, 108, C342, 346) and HPF (L77, 80, C296, 297, 303, 308), then applied to the RF amplifier (Q28) via TX/RX switch (D53, 61, 62). The amplified signals are passed through the RX switch (RL1), attenuator (D28) and tuned BPF (D19, 21, 24, 27), before being applied to another RF amplifier (Q20). The amplified signals are applied to the 1st mixer (IC19) via the another tuned BPF (D11, 13, 15, 17) and RX switch (D8).

While the diversity operation is activated, the received signals are also input from antenna connector ANT-2 (J2). The received signals are passed through the LPF (L103, 106, 109, C344, 348), HPF (L95, 99, C329, 333, 338), antenna switch (D69, 73, 74) and limiter (D63, 66), then applied to the RF amplifier (Q29).

The amplified signals are applied to the RX switch (RL1), and gone through the same process as the received signals from ANT-1 (J1).

• RF CIRCUITS

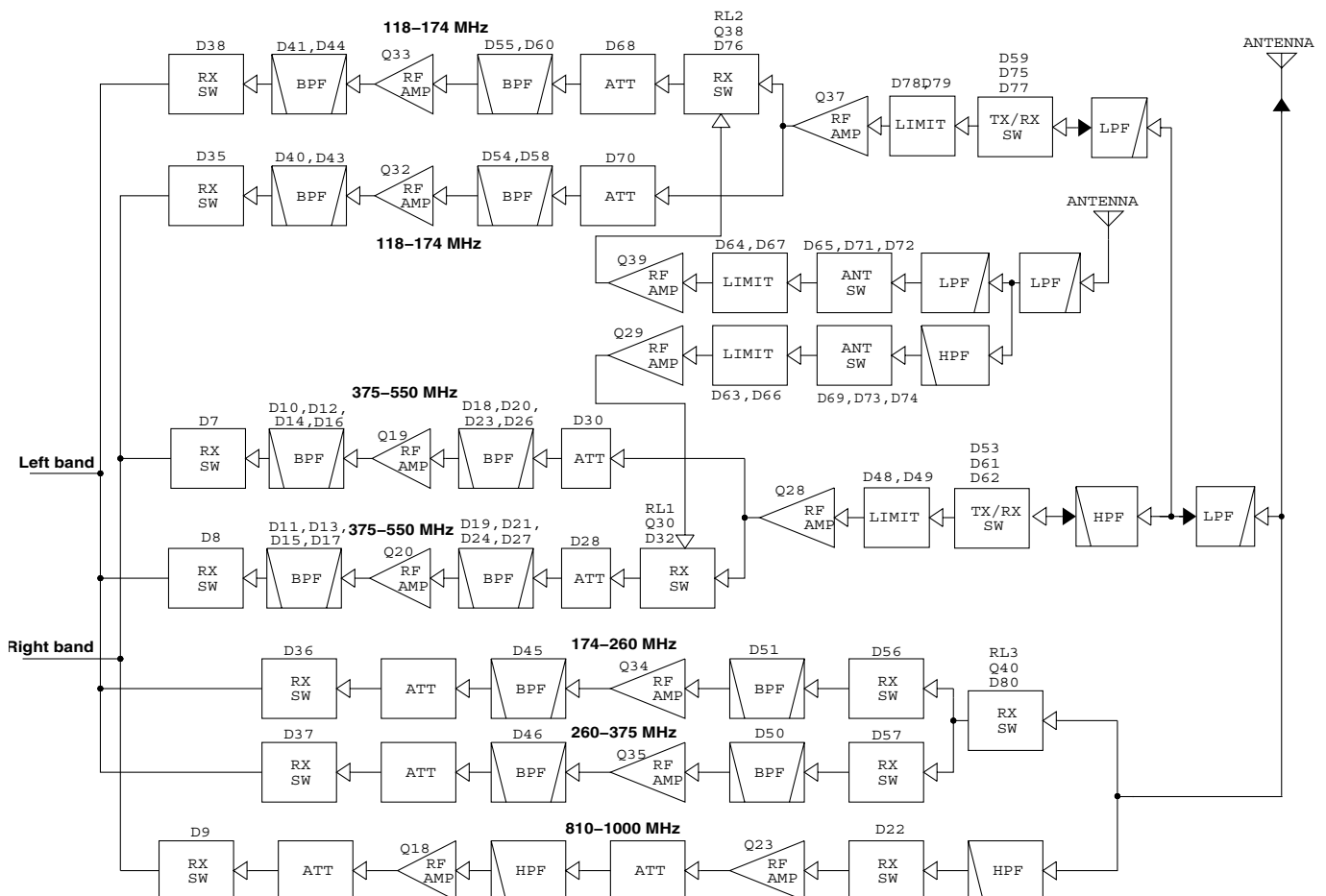

1ST IF CIRCUITS

RX signals from the RF circuits are converted into the 38.85 MHz 1st IF signal by being mixed with LO signals from the left band VCO (Q111, D145-147).

The converted IF signal from the 1st mixer is passed through the IF filter (F15) to be filtered. The filtered IF signal is applied to the 1st IF amplifier (Q66) via the limiter (D88). The amplified 1st IF signal is applied to the IF IC (IC15, pin 16)

2ND IF AND DEMODULATOR CIRCUITS (Fig. 2)

IC15 is an IF IC which contains 2nd mixer, limiter amplifier, noise amplifier, quadrature detector and RSSI circuit, etc. in its package.

The 1st IF signal from the 1st IF amplifier (Q66) is converted into the 450 kHz 2nd IF signal by being mixed with tripled reference frequency signal (38.4 MHz) from the PLL IC (IC41) via the tripler (Q105). The converted 2nd IF signal is output from pin 3, and passed through the ceramic filter (F11 for narrow mode, F12 for wide mode) to remove sideband noise, then applied to the IF IC from pin 5 again.

• FM DEMODULATOR

The filtered 2nd IF signal from pin 5 is amplified at the limiter amplifier, and FM-demodulated at the quadrature detector circuit. The demodulated AF signals are output from pin 9 and routed to the AF circuits via two AF switches (IC11 and IC13).

• AM DEMODULATOR CIRCUITS

In the AM mode, the 2nd IF signal from the F12 is applied to the AM-demodulator circuit (Q55, Q57). The demodulated AF signals are routed to the AF circuits via two AF switches (IC11 and IC13).

SQUELCH CIRCUITS

• NOISE SQUELCH

A portion of FM-demodulated AF signals from the IF IC (IC15, pin 9) are level-adjusted by D/A converter (IC8), and passed through the noise filter (IC15 and some R and C) to be filtered noise components (30 kHz and above signals) in the AF signals. The filtered noise components are detected in the IC15 and output from pin 13, then applied to the CPU (IC25, pin 100) as “L_SQL” signal.

Then the CPU outputs “L_AF_MUTE” signal from pin 82 to the speaker mute switch (Q102), according to the “L_SQL” signal level. Thus the AF line is connected to the GND to turn the AF output OFF.

• CTCSS/DTCS

CTCSS/DTCS signals in the demodulated AF signals from the AF switch (IC13) are passed through the tone filter (Q41). The filtered CTCSS/DTCS signals are applied to the CPU IC25, pin 70) as “L_DTCSIN” signal. The CPU (IC25) compares the applied signal and the set CTCSS/DTCS, then outputs control signal as same as “NOISE SQUELCH.”

• DTMF

DTMF signals in the demodulated AF signals from the AF switch (IC13) are passed through two AF switches (IC57 and IC58), then applied to the DTMF decoder (IC56) to be decoded.

AF CIRCUITS

The AM/FM-demodulated AF signals from the AF switch (IC11) are passed through the AF filter (Q47). The filtered AF signals are applied to the electric volume (IC33) to be adjusted its level. The level-adjusted AF signals are applied to the dual AF power amplifier (IC38) to obtain AF output power level, then applied to the internal (CHASSIS; SP1) or an external speaker via external speaker jack (J7).

If an external speaker is connected to the J8, the level-adjusted AF signals from the electric volume (IC33) are applied to the connected speaker.

• 2ND IF AND DEMODULATOR CIRCUITS (LEFT BAND)

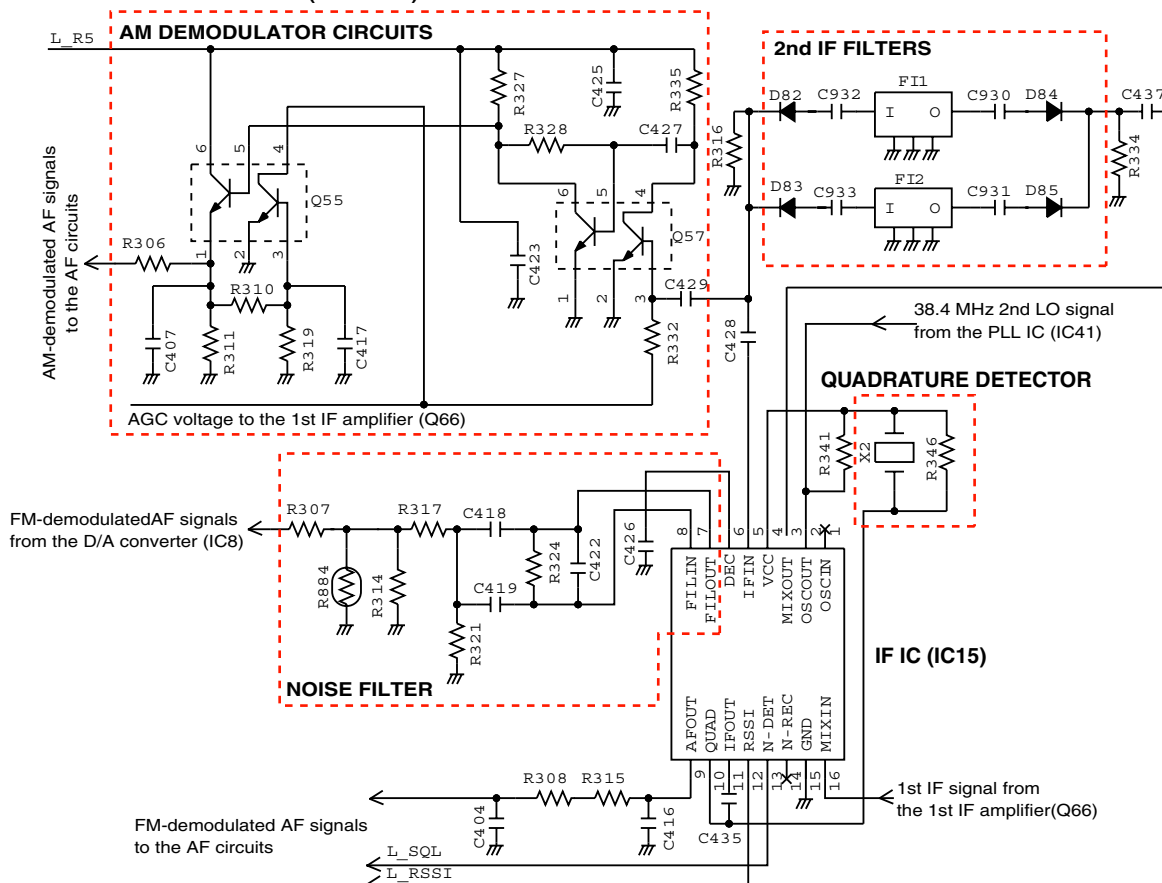

RF CIRCUITS

<Right band>

• 118–174 MHz

The received signals from the antenna connector ANT-1 (J1) are passed through two LPFs (L101, 104, 108, C342, 346; L88, 92, 96, C318, 326, 330), then applied to the RF amplifier (Q37) via TX/RX switch (D59). The amplified signals are passed through the attenuator (D70) and tuned BPF (D54, 58), before being applied to another RF amplifier (Q32). The amplified signals are applied to the 1st mixer (IC20) via the another tuned BPF (D40, 43) and RX switch (D35).

• 375–550 MHz

The received signals from the antenna connector (J1) are passed through the LPF (L101, 104, 108, C342, 346) and HPF (L77, 80, C296, 297, 303, 308), then applied to the RF amplifier (Q28) via TX/RX switch (D53, 61, 62). The amplified signals are passed through the attenuator (D30) and tuned BPF (D18, 20, 23, 26), before being applied to another RF amplifier (Q19). The amplified signals are applied to the 1st mixer (IC20) via the another tuned BPF (D10, 12, 14, 16) and RX switch (D7).

• 810–1000 MHz

The received signals from the ANT-1 (J1) are passed through the HPF (L102, 105, 107, 110, C337, 339, 340, 343, 347, 349) and RX switch (D22), then applied to the RF amplifier (Q23). The amplified signals are passed through the attenuator (R39, 40, 51), and applied to the another RF amplifier (Q18) to be amplified again. The amplified signals are then passed through another attenuator (R14) and RX switch (D9) before being applied to the 1st mixer (IC20).

1ST IF CIRCUITS

RX signals from the RF circuits are converted into the 46.35 MHz 1st IF signal by being mixed with LO signals from the right band VCO (Q72, D89, 90; Q73, D87, 91, 92).

The converted IF signal from the 1st mixer (IC20) is passed through the IF filter (IF6) to be filtered. The filtered IF signal is applied to the 1st IF amplifier (Q75) via the limiter (D100). The amplified 1st IF signal is applied to the IF IC (IC18, pin 16)

2ND IF AND DEMODULATOR CIRCUITS

IC15 is an IF IC which contains 2nd mixer, limiter amplifier, noise amplifier, quadrature detector and RSSI circuit, etc. in its package.

The 1st IF signal from the 1st IF amplifier (Q75) is converted into the 450 kHz 2nd IF signal by being mixed with tripled reference frequency signal (45.9 MHz) from the PLL IC (IC14) via the tripler (Q52). The converted 2nd IF signal is output from pin 3, and passed through the ceramic filter (FI3 for narrow mode, FI4 for wide mode) to remove sideband noise, then applied to the IF IC from pin 5 again.

• FM DEMODULATOR

The filtered 2nd IF signal from pin 5 is amplified at the limiter amplifier, and FM-demodulated at the quadrature detector circuit (X3). The demodulated AF signals are output from pin 9 and routed to the AF circuits via two AF switches (IC12 and IC16).

• AM DEMODULATOR CIRCUITS

In the AM mode, the 2nd IF signal from the FI3 is applied to the AM-demodulator circuit (Q63, Q67). The demodulated AF signals are routed to the AF circuits via two AF switches (IC12 and IC16).

• DEMODULATOR CIRCUITS (Right band)

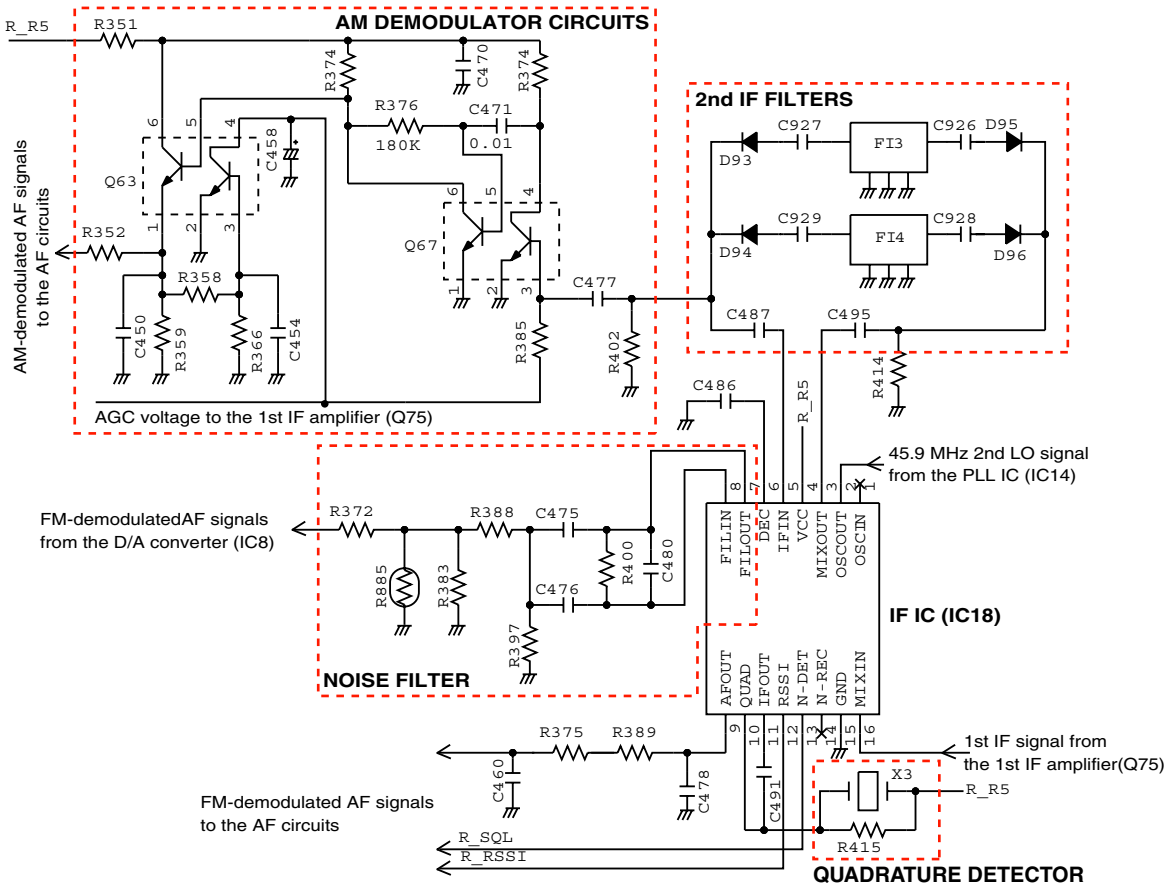

SQUELCH CIRCUITS

• NOISE SQUELCH

A portion of FM-demodulated AF signals from the IF IC (IC18, pin 9) are level-adjusted by D/A converter (IC8), and passed through the noise filter (IC18 and some R and C) to be filtered noise components (30 kHz and above signals) in the AF signals. The filtered noise components are detected in the IC18 and output from pin 13, then applied to the CPU as “R_SQL” signal.

Then the CPU outputs “R_AF_MUTE” signal from pin 51 to the speaker mute switch (Q102), according to the “R_SQL” signal level. Thus the AF line is connected to the GND to turn the AF output OFF.

• CTCSS/DTCS

CTCSS/DTCS signals in the demodulated AF signals from the AF switch (IC16) are passed through the tone filter (Q42). The filtered CTCSS/DTCS signals are applied to the CPU IC12) as “R_DTCS” signal.

The CPU (IC25) compares the applied signal and the set CTCSS/DTCS, then outputs control signal as same as “NOISE SQUELCH.”

• DTMF

DTMF signals in the demodulated AF signals from the AF switch (IC16) are passed through two AF switches (IC57 and IC58), then applied to the DTMF decoder (IC56) to be decoded.

AF CIRCUITS

The AM/FM-demodulated AF signals from the AF switch (IC12) are passed through the AF filter (Q48). The filtered AF signals are applied to the electric volume (IC33) to be adjusted its level. The level-adjusted AF signals are applied to the dual AF power amplifier (IC38) to obtain AF output power level, then applied to the an external speaker via external speaker jack (J8).

**4-2 TRANSMITTER CIRCUITS
MICROPHONE AMPLIFIER CIRCUITS**

The audio signals from the microphone (MIC signals) are applied to the microphone amplifier (IC28) via J2 and HPF (Q87). The amplified MIC signals are passed through the microphone gain switch (Q88) and MIC mute switch (IC30), then passed through or by-passed ALC amplifier (IC32) via AF switches (IC29 and IC52).

The MIC signals from the AF switch (IC52) are passed through the HPF (IC48), LPF (IC48) and AF switch (IC51), and then applied to the AF amplifier (IC48). The amplified MIC signals are applied to the D/A converter (IC8) for level (deviation) adjustment. The level adjusted MIC signals are applied to the VCO as the modulation signals via modulation signal selector.

<OPERATION ON THE LEFT BAND>

The modulation signals are applied to the variable capacitor D147 of the left band VCO (Q111, D145–147) via the modulation selector (IC9) and modulation mute switch (Q109), and modulated. The modulated VCO output are amplified by the buffer (Q113) and LO amplifier (IC44), and applied to the transmit amplifiers as the TX signal, via the LO switches (D155, 157), LPF(L157, C818, 820) and attenuator (R33, 37, 46).

TRANSMIT POWER AMPLIFIERS

TX signal from the attenuator (R33, 37, 46) is amplified by pre-drive (Q25) and drive (Q27) amplifiers to obtain RF level for power module (IC3). The amplified TX signal is applied to the power amplifier which is a VHF band PA module composed by two power MOS-FETs. The power-amplified TX signal is passed through the LPF, power detector, antenna switch (D59) and LPF, before being applied to the antenna connector (CHASSIS; J1).

APC CIRCUITS

A portion of the TX signal from IC3 is rectified at the power detector (D39, D47), and converted into the DC voltage which is in proportion to the RF power, and applied to the operational amplifier (IC4, pin 6). IC4 is an APC amplifier for both of V/UHF bands. The TX power setting voltage “PCON_V” from the D/A converter (IC1, pin 7) is applied to the pin 5 as a reference. IC4 is rolled as a differential amplifier which outputs voltage in inverse proportion to rectified one. When the TX power increased, the rectified voltage also increased, that causes the decrease of output voltage of differential amplifier. The decrease of output voltage of differential amplifier causes the drop of the gate voltage of IC3, Thus the TX power maintained to keep stable level.

TX muting is carried out by TX mute SW (Q36) controlled by “TX_mute” signal. Applying “TX_mute” signal to the base terminal of Q36 to turn it ON, 8 V DC appears on the pin 6 of IC4 and its output voltage downs to 0 V DC to inactivate IC3.

• MICROPHONE AMPLIFIER CIRCUITS

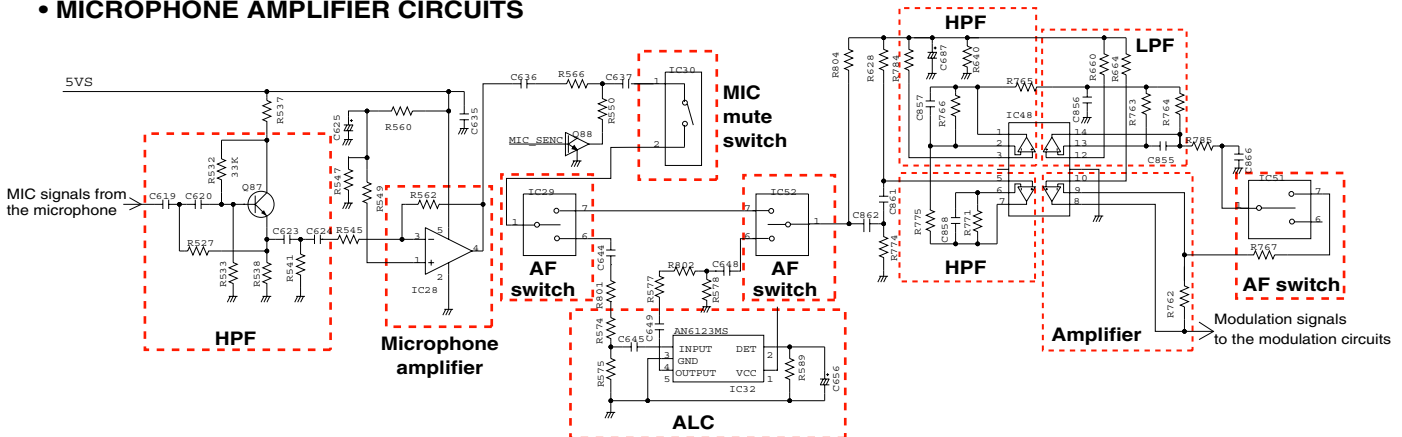

<OPERATION ON THE RIGHT BAND>

The modulation signals are applied to the variable capacitor D87 of the left band VCO (Q73, D87, 91, 92) via the modulation selector (IC63) and modulation mute switch (Q64), and modulated. The modulated VCO output are amplified by the buffer (Q76) and LO amplifier (IC45), and applied to the transmit amplifiers as the TX signal, via the VCO switch (D102). The amplified LO signals are applied to the transmit amplifiers via the LO switch (D103), two HPFs (L124, C527, 532; L159, C533, 535) and attenuator (R43, 47, 57).

TRANSMIT POWER AMPLIFIERS

TX signal from the attenuator (R43, 47, 57) is amplified by pre-drive (Q22) and drive (Q26) amplifiers to obtain RF level for power module (IC2). The amplified TX signal is applied to the power amplifier which is a UHF band PA module composed by two power MOS-FETs. The power-amplified TX signal is passed through the LPF, power detector, antenna switch (D62) and LPF, before being applied to the antenna connector (CHASSIS; J1).

APC CIRCUITS

A portion of the TX signal from IC2 is rectified at the power detector (D42, 52), and converted into the DC voltage which is in proportion to the RF power, and applied to the operational amplifier (IC4, pin 2). IC4 is an APC amplifier for both of V/UHF bands. The TX power setting voltage "PCON_U" from the D/A converter (IC1, pin 6) is applied to the pin 3 as a reference. IC4 is rolled as a differential amplifier which outputs voltage in inverse proportion to rectified one. When the TX power increased, the rectified voltage also increased, that causes the decrease of output voltage of differential amplifier. The decrease of output voltage of differential amplifier causes the drop of the gate voltage of IC2, Thus the TX power maintained to keep stable level.

TX muting is carried out by TX mute SW (Q36) controlled by "TX_mute" signal. Applying "TX_mute" signal to the base terminal of Q36 to turn it ON, 8 V DC appears on the pin 6 of IC4 and its output voltage downs to 0 V DC to inactivate IC3.

• APC CIRCUITS

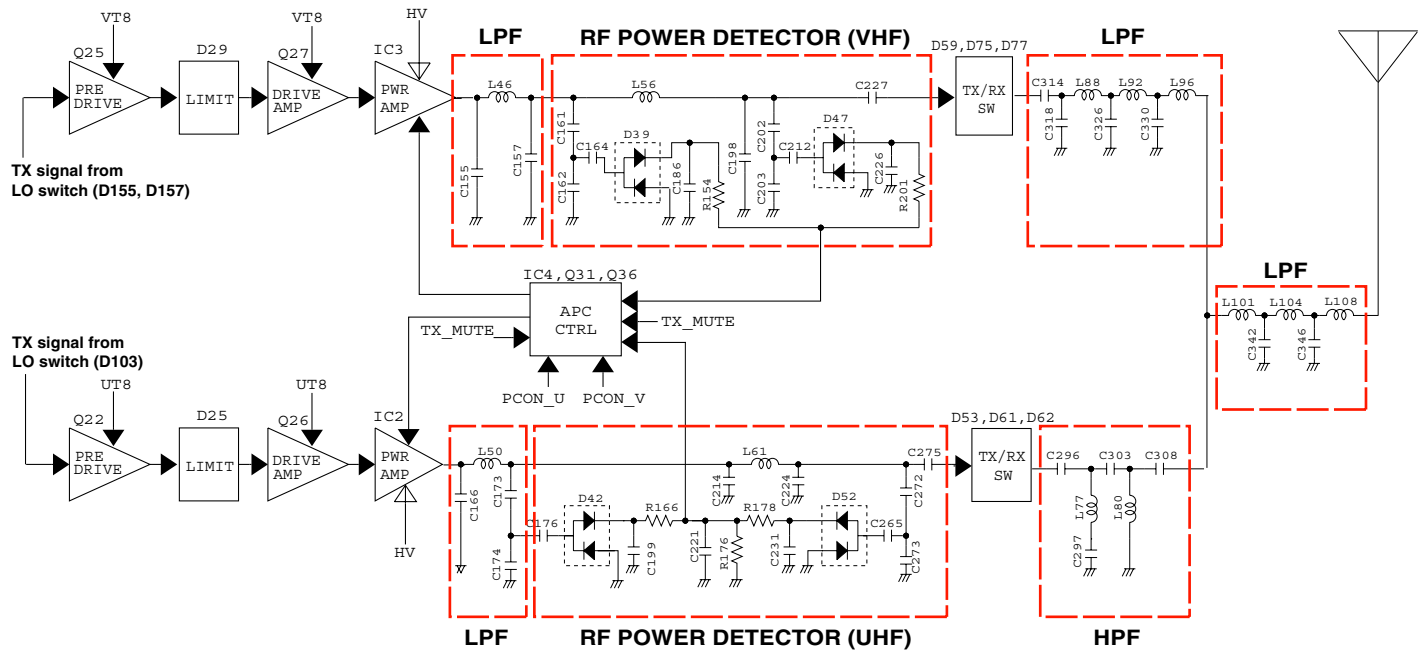

4-3 FREQUENCY SYNTHESIZER

VCOs

This transceiver has 3 VCOs; Left band VCO, Right band RX VCO and Right band TX/RX VCO.

LEFT BAND VCO (Q111, D145–147)

This VCO oscillates 1st LO signals for Left band RX and TX signal for VHF band.

<While receiving>

The VCO output signal is amplified by buffer (Q113) and LO amplifier (IC44), and applied to the LO filters according to the RX frequency.

• While Receiving 118–174 MHz signals

LO signals 135.575–255.575 MHz are applied to the divider (IC43) via LO switch (D150) and attenuator (R706, 710, 711), and divided into 271.15–511.15 MHz signals. The divided LO signals are buffer-amplified by Q116, and applied to the left band 1st mixer (IC19) via the LPF (L115, 156, C809, 812, 816) and another LO switch (D156).

• While Receiving 174–260 MHz signals

LO signals 141.15–221.145 MHz are passed through the LPF (L148, 152, C785, 789, 795, 804) via LO switches (D151, 153), and applied to the left band 1st mixer (IC19).

• While Receiving 375–550 MHz signals

LO signals 135.575–255.575 MHz are doubled to 271.15–511.15 MHz signals, by being passed through the HPF (L149, C787, 790, 791), LPF (L151, C794, 796, 799) and HPF (L153, C800, 807) via LO switches (D152, 154). The doubled LO signals are applied to the left band 1st mixer (IC19).

<While transmitting>

The VCO output signal is amplified by buffer (Q113) and LO amplifier (IC44), and applied to the transmit amplifiers via the LO switches (D155, 157), LPF(L157, C818, 820) and attenuator (R33, 37, 46).

RIGHT BAND RX VCO (Q72, D89, 90)

This VCO oscillates 1st LO signals for right band RX (118–174 MHz and 810–1000 MHz).

The VCO output signal is amplified by buffer (Q74) and applied to the LO amplifier (IC45) via VCO switch (D160), and applied to the LO filters according to the RX frequency.

• While Receiving 118–174 MHz signals

LO signals 164.35–220.35 MHz are passed through the LPF (L123, 125, C529, 534, 539) via LO switches (D107, 159), and applied to the right band 1st mixer (IC20).

• While Receiving 810–1000 MHz signals

LO signals 381.825–476.82 MHz are applied to the LO amplifier (IC62) via LO switch (D101). The amplified LO signals are doubled to 763.65–953.64 MHz signals by being passed through the HPF (L130, 133, C554, 558, 560), LPF (L151, C794, 796, 799) and HPF (L135, C563, 568).

The doubled LO signals are applied to the right band 1st mixer (IC20).

RIGHT BAND TX/RX VCO (Q73, D87, 91, 92)

This VCO oscillates 1st LO signals for right band RX (375–550 MHz).

<While receiving>

LO signals 353.65–523.17 MHz are passed through the RF mute switch (Q79) and LPF (L131, 134, C562) via LO switches (D104, 108), and applied to the right band 1st mixer (IC20).

<While transmitting>

The VCO output signal is amplified by buffer (Q76), and applied to the LO amplifier (IC45) via the VCO switch (D102). The amplified LO signals are applied to the transmit amplifiers via the LO switch (D103), two HPFs (L124, C527, 532; L159, C533, 535) and attenuator (R43, 47, 57).

• VCO CONFIGURATION BY FREQUENCY

VCO		LEFT BAND VCO	RIGHT BAND RX VCO	RIGHT BAND TX/RX VCO	
Components		(Q111, D145–147)	(Q72, D89, 90)	(Q73, D87, 91, 92)	
Oscillating Frequency	RX	(118–174 MHz)	135.575–255.575 MHz	164.35–220.35 MHz	–
		(174–260 MHz)	141.15–221.145 MHz	381.825–476.82 MHz	–
		(375–550 MHz)	135.575–255.575 MHz	–	353.65–523.17 MHz
	TX	136–174 MHz	–	400–470 MHz	

PLL CIRCUITS

The PLL circuit provides stable oscillation of the transmit frequency and receive 1st LO frequency. The PLL output frequency is controlled by the divided ratio (N-data) from the CPU.

LEFT BAND VCO LOOP

A portion of VCO output signals from the buffer (Q113) are applied to the PLL IC (IC41) via another buffer (Q112). The applied signals are divided at the prescaler and programmable counter according to the control signals ("L_PLLSTB," "PLLDATA" and "PLLCK") from the CPU. The divided signal is phase-compared with the 12.8 MHz reference frequency signal from the reference frequency oscillator (X5), at the phase detector.

The phase difference is output from pin 5 as a pulse type signal after being passed through the internal charge pump. The output signal is converted into the DC voltage (lock voltage) by passing through the loop filter (R694, 696–698, C760–762). The lock voltage is applied to the variable capacitors (D145 and D146), and locked to keep the VCO frequency constant.

If the oscillated signal drifts, its phase changes from that of the reference frequency, causing a lock voltage change to compensate for the drift in the VCO oscillating frequency.

• LEFT BAND VCO LOOP

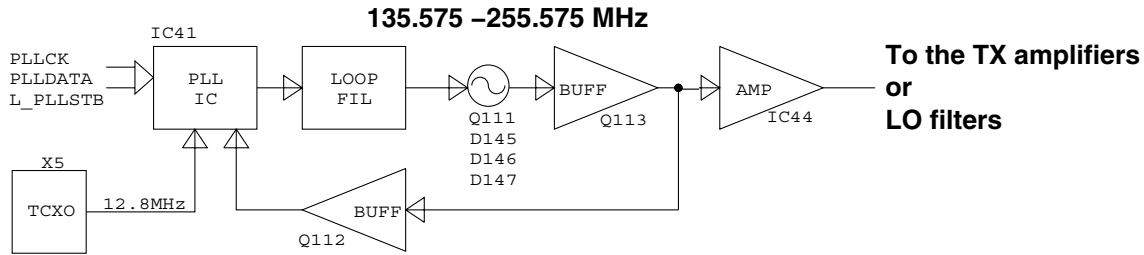

RIGHT BAND RX VCO LOOP

A portion of VCO output signals from the buffer (Q74) are applied to the PLL IC (IC14) via the VCO switch (D160) and another buffer (Q112). The applied signals are divided at the prescaler and programmable counter according to the control signals ("R_PLLSTB," "PLLDATA" and "PLLCK") from the CPU. The divided signal is phase-compared with the 15.3 MHz reference frequency signal from the reference frequency oscillator (X1), at the phase detector.

RIGHT BAND TX/RX VCO

A portion of VCO output signals from the buffer (Q76) are applied to the PLL IC (IC14) via the VCO switch (D102) and another buffer (Q60). The applied signals are divided at the prescaler and programmable counter according to the control signals ("R_PLLSTB," "PLLDATA" and "PLLCK") from the CPU. The divided signal is phase-compared with the 15.3 MHz reference frequency signal from the reference frequency oscillator (X1), at the phase detector.

The phase difference is output from pin 5 as a pulse type signal after being passed through the internal charge pump. The output signal is converted into the DC voltage (lock voltage) by passing through the loop filter (Q61, 62, D86). The lock voltage is applied to the variable capacitors (D91, 92), and locked to keep the VCO frequency constant.

The phase difference is output from pin 5 as a pulse type signal after being passed through the internal charge pump. The output signal is converted into the DC voltage (lock voltage) by passing through the loop filter (Q61, 62, D86). The lock voltage is applied to the variable capacitors (D91, 92), and locked to keep the VCO frequency constant.

• RIGHT BAND RX AND TX/RX VCO LOOP

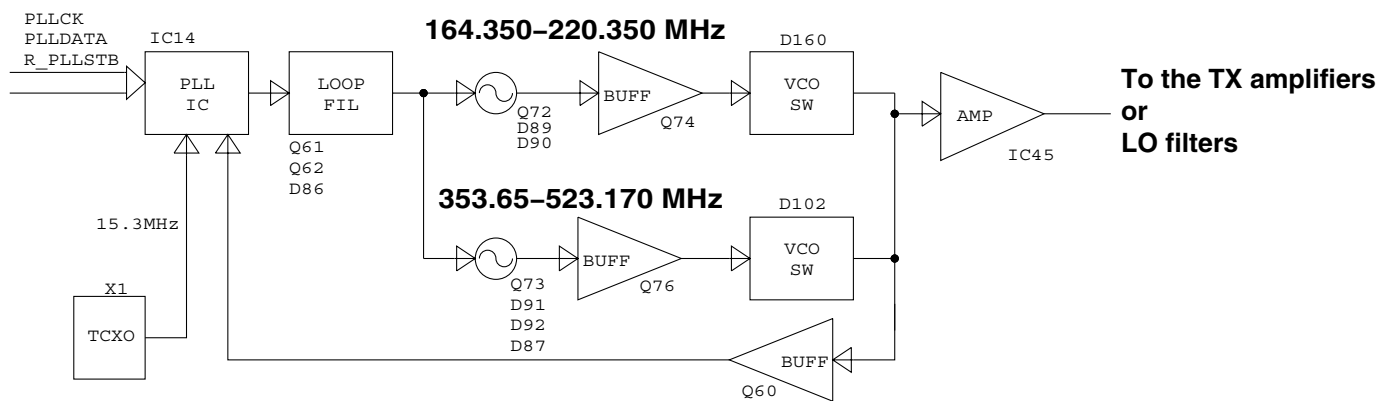

4-4 POWER SUPPLY CIRCUITS

Voltage from the power supply is routed to whole of the circuit in the transceiver via switches and regulators.

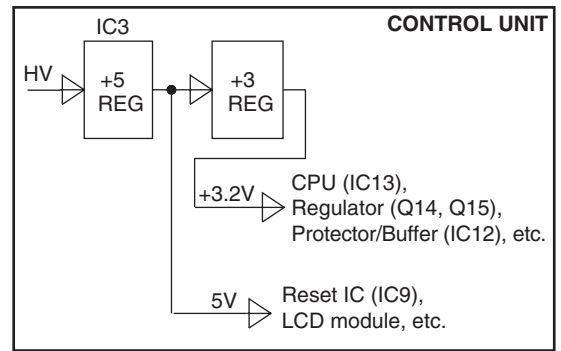
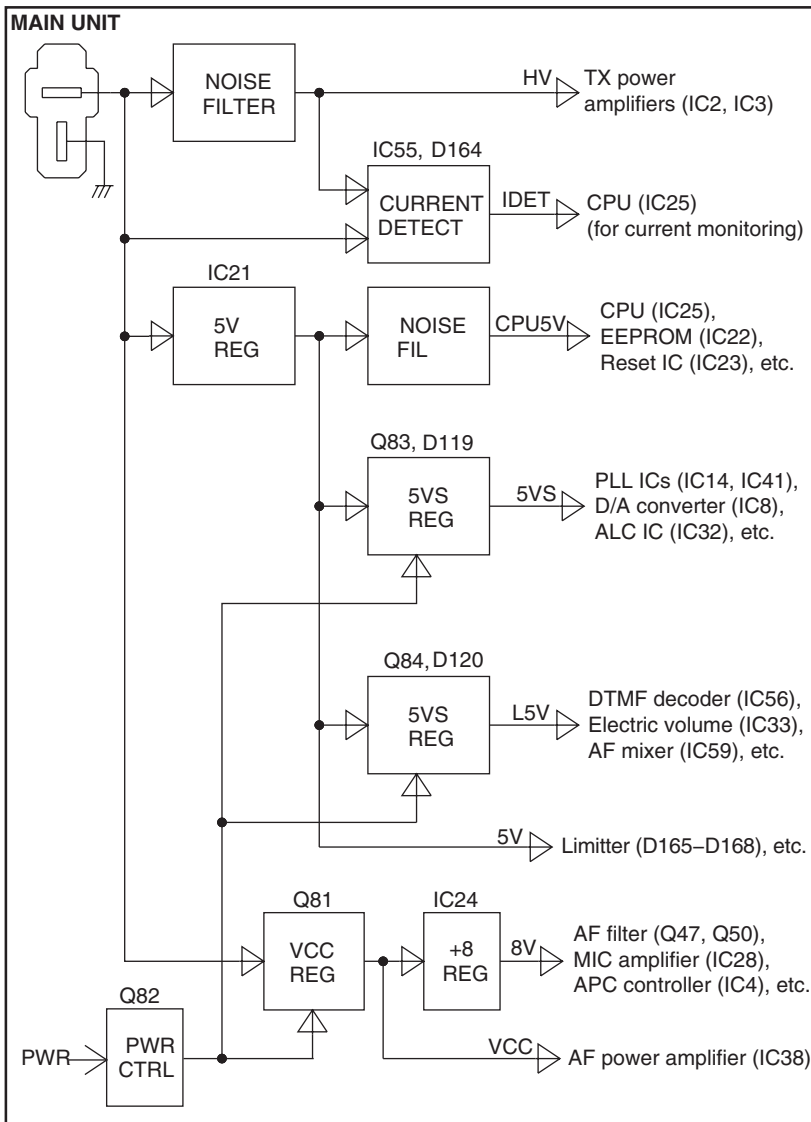

4-5 CPU PORT ALLOCATION

PIN No.	PORT NAME	DESCRIPTION	I/O
3	AN	Cut-off frequency shifting signal to the HPF (IC48).	O
4	DA_SEL	Cut-off frequency shifting signal to the HPF (IC48).	O
5	MM_MUTE	MIC mute signal to the MIC mute switch (IC30). "H"=MIC mute.	O
6	DCONT	ALC amplifier control signal tot the AF switches (IC29 and IC52). "H"=ALC amplifier ON.	O
7	R_WN_SEL	2nd IF filter (Right band; Wide/Narrow) toggling signal. "H"=Narrow. "L"=Wide.	O
11	MIC_SENC	Microphone sensitivity select signal. "H"=High sensitivity.	O
17	MOD_DA	Modulation line switching signal to the MOD selector (Left band; IC9). "H"=Modulation enable.	O
18	MODSEL	Modulation line switching signal to the MOD selector (Right band; IC63). "H"=Modulation enable.	O
21	R_PLLSTB	Strobe signal to the PLL IC (Right band; IC14).	O
22	L_PLLSTB	Strobe signal to the PLL IC (Left band; IC41).	O
23	L_AMC	AM-demodulator circuit (Left band) control signal. "H"=AM mode (AM-modulator circuit is activated).	O
24	DTCS_SEL	Tone filter switching signal to the LPF (Q100). "H"=DTCS mode. "L"=CTCSS mode.	O
25	L_R5C	RX circuits (Left band) control signal. "H"=RX circuits (Left band) is activated.	O
26	L_WN_SEL	2nd IF filter (Wide/Narrow) toggling signal.(Left band) "H"=Narrow. "L"=Wide."	O
27	UMMUTE	Modulation mute signal to the MOD mute switch (Right band; Q64). "H"=Modulation muted.	O
28	UTX_C	Transmitting control signal to the VT8 regulator (Q12, 15).	O
29	L_VCO_SHIFT	VCO oscillating frequency shift signal to the Left band VCO.	O
30	R_PLLSW	Lock-up time control signal to the loop filter (Right band). "H"=Fast lock-up time.	O
31	R_UNLOCK	PLL unlock signal from the PLL IC (Right band; IC14).	I
32	PLLCK	Clock signal to the PLL ICs (Right band; IC14, Left band; IC41). (Commonly used for both of the Left and Right bands.)	O
33	PLLDATA	Data to the PLL ICs (Right band; IC14, Left band; IC41). (Commonly used for both of Left and Right bands.)	O
34	L_UNLOCK	PLL unlock signal from the PLL IC (Left band; IC41).	I
35	VMMUTE	Modulation mute signal to the MOD mute switch (Left band; Q109). "H"=Modulation muted.	O
36	VTX_C	Transmitting control signal to the UT8 regulator (Q13, 17). "H"=While transmitting.	O
37	L_PLLSW	Lock-up time control signal to the loop filter (left band). "H"=Fast lock-up time.	O

PIN No.	PORT NAME	DESCRIPTION	I/O
38	R_UVCO_SEL	VCO power control signal to the VCO select switch (Right band UHF; Q65, 68). "L"=Right band TX/RX VCO is activated.	O
39	R_VVCO_SEL	VCO power control signal to the VCO select switch (Right band VHF; Q65, 68). "L"=Right band RX VCO is activated.	O
40	L_LO_SW	LO filter switching signal to the LO regulator (Q106).	O
42	R_DA_SEL	AF line switching signal to the AF switch (IC12).	O
42	R_AFFIL_SEL	Switching signal to the AF filter (Right band; Q48).	O
43	R_DET_MUTE	AF line switching signal to the AF switch (IC16). "H"=AF mute.	O
44	L_DA_SEL	AF line switching signal to the AF switch (IC11).	O
45	L_DET_MUTE	AF line switching signal to the AF switch (IC13). "H"=AF mute.	O
48	D5VC	Power control signal for the optional unit.	O
51	R_AF_MUTE	AF mute signal to the SP mute switch (Right band; Q101). "H"=AF mute.	O
52	L_AFFIL_SEL	Switching signal to the AF filter (Left band; Q47).	O
53	DA3STB	Strobe signal to the D/A converter.	O
53	DA2_STB	Strobe signal to the electric volume.	O
55	DTCS	DTCS signal.	O
56	DTMF	DTMF signal.	O
57	MIC_SEL	Connected microphone detect signal.	I
61	DTMSTB	Strobe signal to the DTMF decoder (IC56).	-
62	MICUD	[UP]/[DWN] key input.	I
63	R_RSLV	While receiving; inputs RSSI signal (IC18; Right band). While transmitting; inputs Lock Voltage from the PLL IC (IC14).	I
64	L_RSLV	While receiving; inputs RSSI signal from IF ICI (IC15; Left band). While transmitting; inputs Lock Voltage from the PLL IC (IC41).	I
65	IDET	Current level from the current detector (IC55, Q164).	I
68	R_DTCS_IN	Demodulated DTCS signals from the CTCSS filter (Q42).	I
70	L_DTCS_IN	Demodulated DTCS signals from the CTCSS filter (Q41).	I
71	TEMP	Transceiver's internal temperature from the thermal detector circuit (R509).	I
76	SCL	I/O port for clock signal to the EEPROM (IC22).	I/O
77	AF_VOL_CK	Serial clock signal to the electric volume IC.	O
78	AF_VOL_DATA	Data signal to the electric volume IC.	O
79	AF_VOL_STB	Latch enable signal to the electric volume IC.	O
80	AF_VOL_RES	Reset signal to the electric volume IC.	O
80	PWR	Power control signal to the PWR controller (Q82). "H"=While the power is ON.	O
82	SDA	Data signal to the EEPROM (IC22).	I/O
83	L_AF_MUTE	AF mute signal to the SP mute switch (Q102).	O
85	MIC_PTT	Input port for [PTT] key on the connected microphone.	I

PIN No.	PORT NAME	DESCRIPTION	I/O
100	RESET	Reset enable signal input.	I
101	L_SQL	Noise signal from the IF IC (Left band; IC15).	I
102	CL_SFT2	Clock frequency shifting signal.	O
105	R_SQL	Noise signal from the IF IC (Right band; IC18).	I
122	R_DATA	Data lines for the control unit.	I
123	TX_DATA	Data lines for the control unit.	O
127	TX232	Data bus for RS-232C communication.	O
128	RX232	Data bus for RS-232C communication.	I
129	DA_CK	Serial clock signal to the D/A converter.	O
130	DA_DATA	Serial data to the D/A converter.	O
134	DA_STB	Strobe signal to the D/A converter.	O
135	R_R5C	RX circuits (Right band) control signal.	O
136	R400_S	Power line control signal to the 375–550 MHz band RF circuit (Right band).	O
137	R_RX800	Power line control signal to the 810–1000 MHz band RF circuit (Right band).	O
138	R_AMC	AM-demodulator circuit (Right band) control signal.	O
143	DTMSD	Data to the DTMF decoder (IC56).	-
144	DTMCK	Clock signal to the DTMF decoder (IC56).	-

SECTION 5 ADJUSTMENT PROCEDURE

5-1 PREPARATION

REQUIRED TEST EQUIPMENTS

When adjusting IC-E2820, following test equipments and JIG cable (modified 8-pin modular jack; see the illust below) are required.

EQUIPMENT	GRADE AND RANGE	EQUIPMENT	GRADE AND RANGE
DC power supply	Output voltage : 13.8 V DC Current capacity : More than 20 A	Audio generator	Frequency range : 300–3000 Hz Output level : 1–500 mV
RF power meter (terminated type)	Measuring range : 1–100 W Frequency range : 100–600 MHz Impedance : 50 Ω SWR : Less than 1.2 : 1	Standard signal generator (SSG)	Frequency range : 0.1–1 GHz Output level : 0.1 μV to 32 mV (–127 to –17 dBm)
Frequency counter	Frequency range : 0.1–600 MHz Frequency accuracy: ±1 ppm or better Sensitivity : 100 mV or better	AC millivoltmeter	Measuring range : 10 mV to 10 V
		Terminator	Impedance : 50 Ω Capacity : More than 100 W
Modulation Analyzer	Frequency range : 30–600 MHz Measuring range : DC to ±10 kHz	Attenuator	Power attenuation : 40 dB Capacity : More than 100 W

JIG CABLE

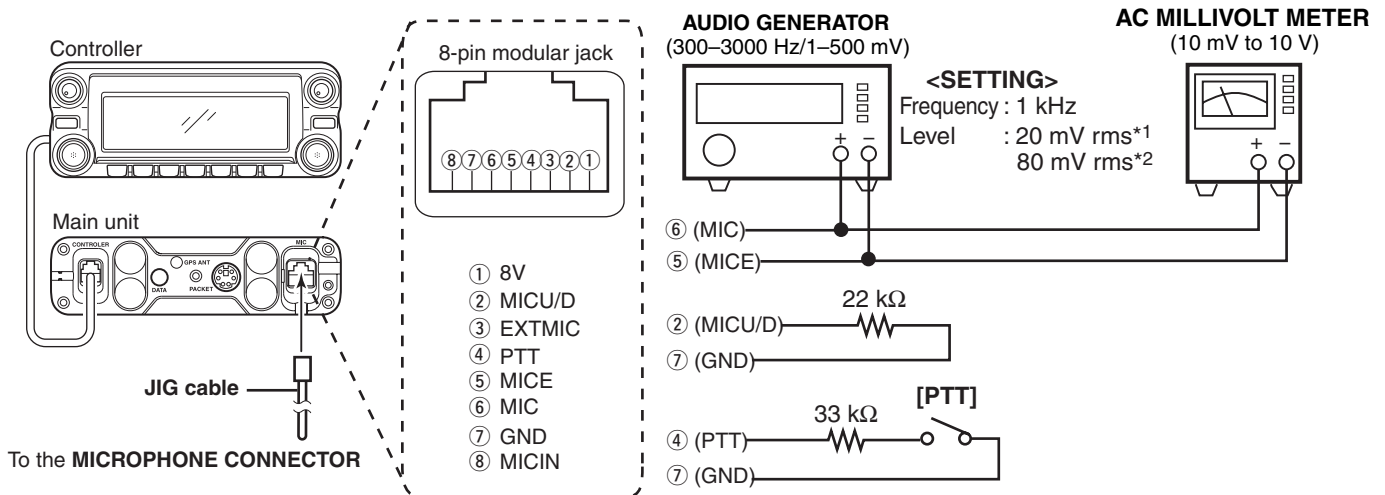

ENTERING ADJUSTMENT MODE

- ① Connect the JIG cable to the **MICROWAVE CONNECTOR** (see the illust above).
- ② Push and hold the both of **[MAIN•BAND]** keys, then turn power ON.

KEY ASSIGNMENTS IN THE ADJUSTMENT MODE

Entering adjustment mode, the function display shows adjustment item and conditions as below.

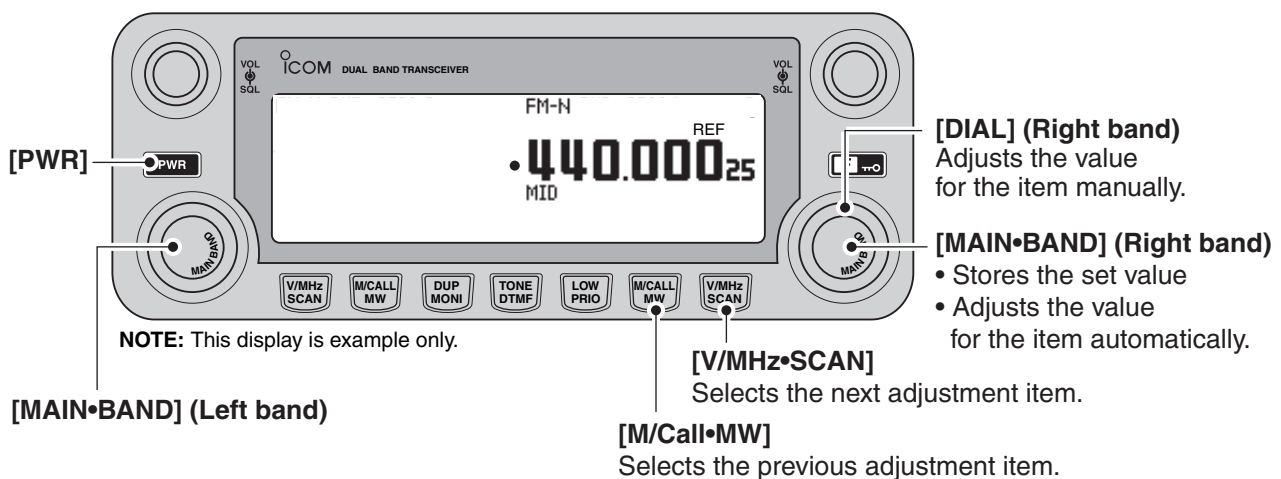

5-2 FREQUENCY ADJUSTMENT

• CONNECTIONS FOR FREQUENCY ADJUSTMENT

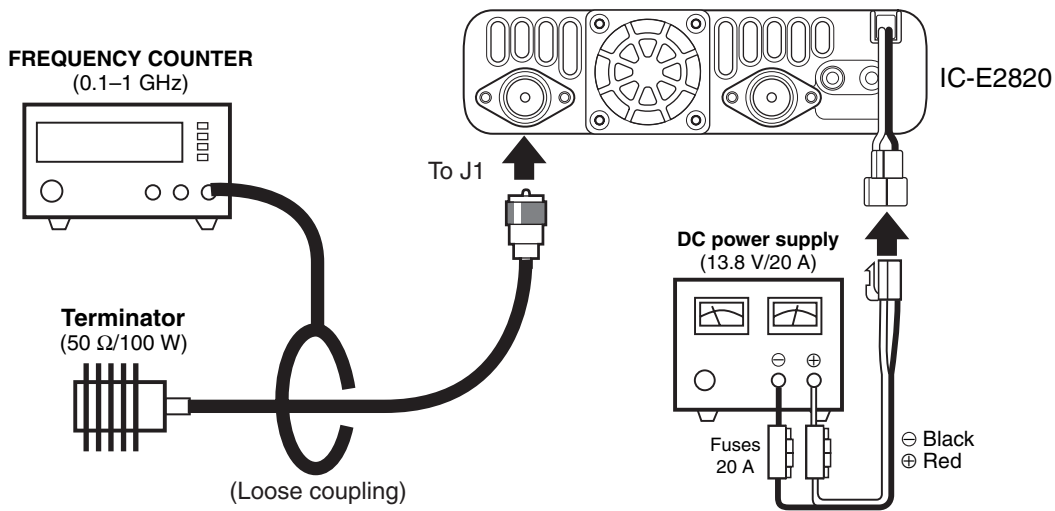

ADJUSTMENT		ADJUSTMENT CONDITIONS	OPERATION	VALUE
REFERENCE FREQUENCY (Left Band) [L REF]	1	<ul style="list-style-type: none"> • Connect a Terminator to the antenna connector (J1). • Loosely couple a Frequency Counter to the antenna connector (J1). • Transmitting 	Rotate the right band's [DIAL] to adjust the reference frequency, then push the right band's [MAIN •BAND] key.	146.000 MHz
(Right Band) [R REF]	2			435.000 MHz

5-3 TRANSMIT ADJUSTMENTS

■ TRANSMIT OUTPUT POWER ADJUSTMENT

• CONNECTIONS FOR TX POWER ADJUSTMENT

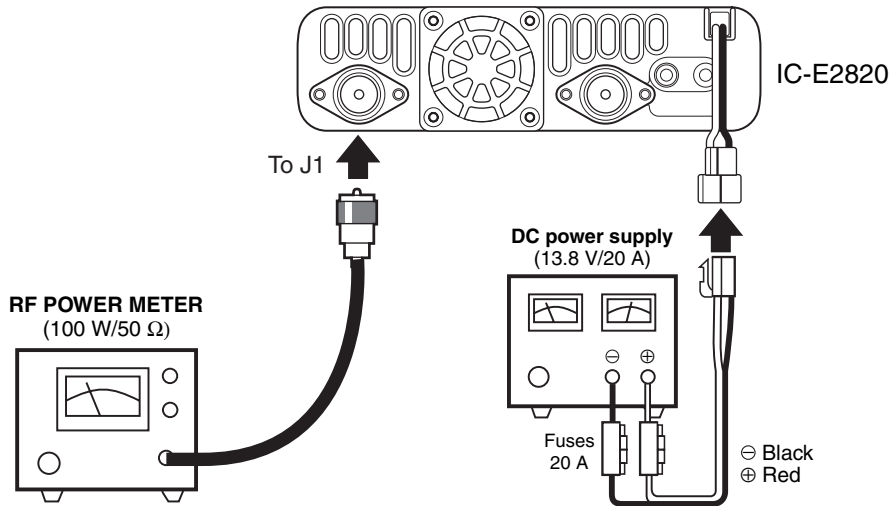

ADJUSTMENT ITEM		ADJUSTMENT CONDITIONS		OPERATION	VALUE
144 MHz BAND TRANSMIT OUTPUT POWER (HI POWER)	(Band Low) [L PHL]	1	<ul style="list-style-type: none"> Connect an RF Power Meter to the antenna connector (J1). Transmitting 	Rotate the right band's [DIAL] to adjust the transmit output power, then push the right band's [MAIN •BAND] key during transmit.	50 W
	(Band High) [L PHH]	2			15 W
(MID POWER)	(Band Low) [L PML]	3			5 W
	(Band High) [L PMH]	4			
(LOW POWER)	(Band Low) [L PLL]	5			
	(Band High) [L PLH]	6			
430 MHz BAND TRANSMIT OUTPUT POWER (HI POWER)	(Band Low) [R PHL]	1	<ul style="list-style-type: none"> Connect an RF Power Meter to the antenna connector (J1). Transmitting 	Rotate the right band's [DIAL] to adjust the transmit output power, then push the right band's [MAIN •BAND] key during transmit.	50 W
	(Band High) [R PHH]	2			15 W
(MID POWER)	(Band Low) [R PML]	3			5 W
	(Band High) [R PMH]	4			
(LOW POWER)	(Band Low) [R PLL]	5			
	(Band High) [R PHH]	6			

■ DEVIATION ADJUSTMENT

• CONNECTION FOR MODULATION ADJUSTMENTS

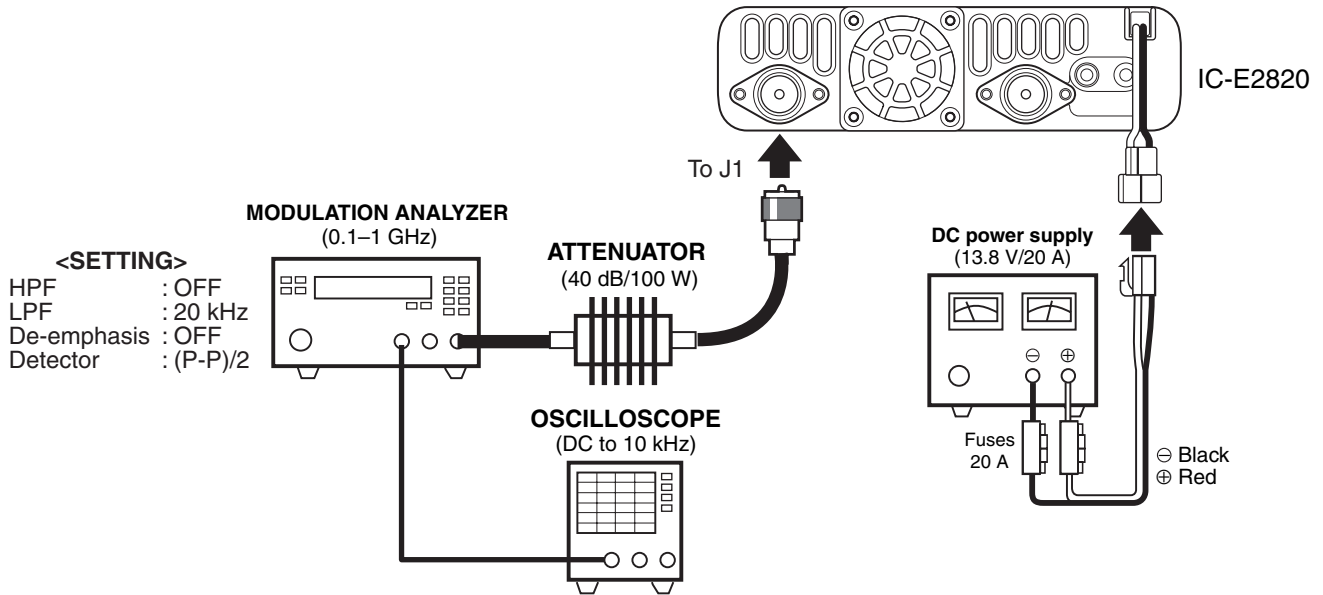

ADJUSTMENT ITEM			ADJUSTMENT CONDITIONS	OPERATION	VALUE	
144 MHz BAND BAND DEVIATION (Left Band)	(Band Low)	(FM) [L FMD]	1	<ul style="list-style-type: none"> Connect a Modulation Analyzer to the antenna connector (J1) through an attenuator. Connect an Audio Generator to the JIG cable (See the page 5-1 for the connector and setting details). Transmitting 	Rotate the right band's [DIAL] to adjust the deviation, then push the right band's [MAIN•BAND] key during transmit.	±4.2 kHz
		(FM-N) [L FMD]	2			±2.1 kHz
	(Band Center)	(FM) [L FMD]	3			±4.2 kHz
		(FM-N) [L FMD]	4			±2.1 kHz
	(Band High)	(FM) [L FMD]	5			±4.2 kHz
		(FM-N) [L FMD]	6			±2.1 kHz
144 MHz BAND MODULATION BALANCE (Left Band)	(Band Low)	(FM) [L FMB]	1	<ul style="list-style-type: none"> Connect a Modulation Analyzer to the antenna connector (J1) through an attenuator. Connect an oscilloscope to the detector terminal of the Modulation Analyzer. No audio signals are applied to the JIG cable (See the page 5-1). Transmitting 	Rotate the right band's [DIAL] to adjust the wave form, then push the right band's [MAIN•BAND] key during transmit.	(Square Wave form)
		(FM-N) [L FMB]	2			
	(Band Center)	(FM) [L FMB]	3			
		(FM-N) [L FMB]	4			
	(Band High)	(FM) [L FMB]	5			
		(FM-N) [L FMB]	6			
144 MHz BAND DTCS MODULATION (Left Band)	(FM) [L MDT]	1	<ul style="list-style-type: none"> Connect a Modulation Analyzer to the antenna connector (J1) through an attenuator. No audio signals are applied to the JIG cable (See the page 5-1). Transmitting 	Rotate the right band's [DIAL] to adjust the deviation, then push the right band's [MAIN•BAND] key.	±0.8 kHz	
	(FM-N) [L MDT]	2				
144 MHz CTCSS MODULATION (Left Band)	(FM) [L MCT]	1	<ul style="list-style-type: none"> Connect a Modulation Analyzer to the antenna connector (J1) through an attenuator. No audio signals are applied to the JIG cable (See the page 5-1). Transmitting 	Rotate the right band's [DIAL] to adjust the deviation, then push the right band's [MAIN•BAND] key.	±0.75 kHz	
	(FM-N) [L MCT]	2				

DEVIATION ADJUSTMENT (continued)

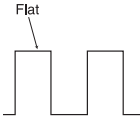
ADJUSTMENT ITEM			ADJUSTMENT CONDITIONS	OPERATION	VALUE	
430 MHz DEVIATION (Right Band)	(Band Low)	(FM) [R FMD]	1	<ul style="list-style-type: none"> Connect a Modulation Analyzer to the antenna connector (J1) through an attenuator. Connect an Audio Generator to the JIG cable (See the page 5-1 for the connector and setting details). Transmitting 	Rotate the right band's [DIAL] to adjust the deviation, then push the right band's [MAIN•BAND] key during transmit.	±4.2 kHz
		(FM-N) [R FMD]	2			±2.1 kHz
	(Band Center)	(FM) [R FMD]	3			±4.2 kHz
		(FM-N) [R FMD]	4			±2.1 kHz
	(Band High)	(FM) [R FMD]	5			±4.2 kHz
		(FM-N) [R FMD]	6			±2.1 kHz
430 MHz MODULATION BALANCE (Right Band)	(Band Low)	(FM) [R FMB]	1	<ul style="list-style-type: none"> Connect a Modulation Analyzer to the antenna connector (J1) through an attenuator. No audio signals are applied to the JIG cable (See the page 5-1). Transmitting 	Rotate the right band's [DIAL] to adjust the wave form, then push the right band's [MAIN•BAND] key during transmit.	(Square Wave form) 
		(FM-N) [R FMB]	2			
	(Band Center)	(FM) [R FMB]	3			
		(FM-N) [R FMB]	4			
	(Band High)	(FM) [R FMB]	5			
		(FM-N) [R FMB]	6			
430 MHz DTCS MODULATION (Right Band)	(FM) [R MDT]	1	<ul style="list-style-type: none"> Connect a Modulation Analyzer to the antenna connector (J1) through an attenuator. No audio signals are applied to the JIG cable (See the page 5-1). Transmitting 	Rotate the right band's [DIAL] to adjust the deviation, then push the right band's [MAIN•BAND] key.	±0.8 kHz	
	(FM-N) [R MDT]	2				
430 MHz CTCSS MODULATION (Right Band)	(FM) [R MCT]	1	<ul style="list-style-type: none"> Connect a Modulation Analyzer to the antenna connector (J1) through an attenuator. No audio signals are applied to the JIG cable (See the page 5-1). Transmitting 	Rotate the right band's [DIAL] to adjust the deviation, then push the right band's [MAIN•BAND] key.	±0.75 kHz	
	(FM-N) [R MCT]	2				
DV MODE DEVIATION* (144 MHz Band)	(Band Low)	[L MDS]	1	<ul style="list-style-type: none"> Connect a Modulation Analyzer to the antenna connector (J1) through an attenuator. Transmitting 	Rotate the right band's [DIAL] to adjust the deviation, then push the right band's [MAIN•BAND] key during transmit.	±0.9 kHz
	(Band Center)	[L MDS]	2			
	(Band High)	[L MDS]	3			
DV MODE MODULATION BALANCE* (144 MHz Band)	(Band Low)	[L MDB]	1	<ul style="list-style-type: none"> Connect a Modulation Analyzer to the antenna connector (J1) through an attenuator. Transmitting 	Rotate the right band's [DIAL] to adjust the wave form, then push the right band's [MAIN•BAND] key during transmit.	Minimum deviation
	(Band Center)	[L MDB]	2			
	(Band High)	[L MDB]	3			
DV MODE DEVIATION* (430 MHz Band)	(Band Low)	[R MDS]	1	<ul style="list-style-type: none"> Connect a Modulation Analyzer to the antenna connector (J1) through an attenuator. Transmitting 	Rotate the right band's [DIAL] to adjust the wave form, then push the right band's [MAIN•BAND] key during transmit.	±1 kHz
	(Band Center)	[R MDS]	2			
	(Band High)	[R MDS]	3			
DV MODE MODULATION BALANCE* (430 MHz Band)	(Band Low)	[R MDB]	1	<ul style="list-style-type: none"> Connect a Modulation Analyzer to the antenna connector (J1) through an attenuator. Transmitting 	Rotate the right band's [DIAL] to adjust the wave form, then push the right band's [MAIN•BAND] key during transmit.	Minimum deviation
	(Band Center)	[R MDB]	2			
	(Band High)	[R MDB]	3			

*; Optional UT-123 is required.

5-4 RECEIVE ADJUSTMENTS

■ SENSITIVITY ADJUSTMENT

• CONNECTION FOR RECEIVE SENSITIVITY AND RSSI ADJUSTMENTS

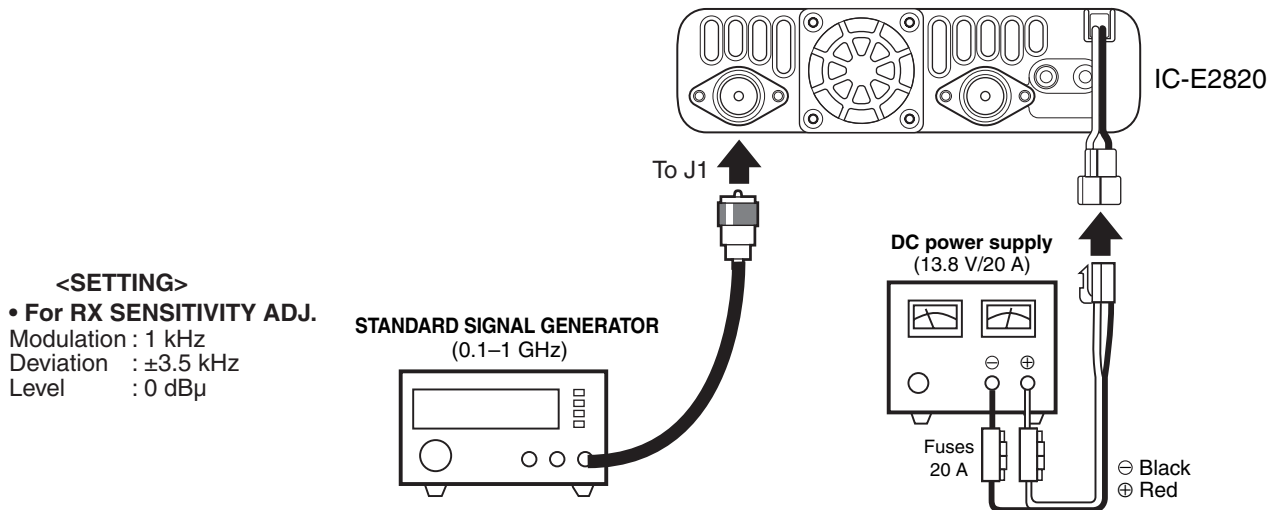

ADJUSTMENT ITEM	ADJUSTMENT CONDITIONS		OPERATION	VALUE
SENSITIVITY	Connect a Standard Signal Generator to the antenna connector (J1).			
118.020 MHz	(Left Band) [L LT1]	1	• Set the SSG as; Frequency : 118.020 MHz	(Automatic adjustment)
	(Right Band) [R LT1]	2		
127.020 MHz	(Left Band) [L MT1]	3	• Set the SSG as; Frequency : 127.020 MHz	
	(Right Band) [R MT1]	4		
135.980 MHz	(Left Band) [L HT1]	5	• Set the SSG as; Frequency : 135.980 MHz	
	(Right Band) [R HT1]	6		
136.020 MHz	(Left Band) [L LT2]	7	• Set the SSG as; Frequency : 136.020 MHz	
	(Right Band) [R LH2]	8		
146.020 MHz	(Left Band) [L MT2]	9	• Set the SSG as; Frequency : 146.020 MHz	
	(Right Band) [R MT2]	10		
173.980 MHz	(Left Band) [L HT2]	11	• Set the SSG as; Frequency : 173.980 MHz	
	(Right Band) [R HT2]	12		
174.020 MHz	(Left Band) [L LT3]	13	• Set the SSG as; Frequency : 174.020 MHz	
220.020 MHz	(Left Band) [L MT3]	14	• Set the SSG as; Frequency : 220.020 MHz	
250.020 MHz	(Left Band) [L HT3]	15	• Set the SSG as; Frequency : 250.020 MHz	
260.020 MHz	(Left Band) [L LT4]	16	• Set the SSG as; Frequency : 260.020 MHz	
310.020 MHz	(Left Band) [L MT4]	17	• Set the SSG as; Frequency : 310.020 MHz	
360.020 MHz	(Left Band) [L HT4]	18	• Set the SSG as; Frequency : 360.020 MHz	

■ SENSITIVITY ADJUSTMENT (continued)

ADJUSTMENT ITEM				ADJUSTMENT CONDITIONS	OPERATION	VALUE
SENSITIVITY	375.020 MHz	(Left Band) [L LT5]	19	• Set the SSG as; Frequency : 375.020 MHz	Push the right band's [MAIN•BAND] key.	(Automatic adjustment)
		(Right Band) [R LT5]	20			
	399.980 MHz	(Left Band) [L HT5]	21	• Set the SSG as; Frequency : 399.980 MHz		
		(Right Band) [R HT5]	22			
	400.020 MHz	(Left Band) [L LT6]	23	• Set the SSG as; Frequency : 400.020 MHz		
		(Right Band) [R LT6]	24			
	440.020 MHz	(Left Band) [L MT6]	25	• Set the SSG as; Frequency : 440.020 MHz		
		(Right Band) [R MT6]	26			
	449.980 MHz	(Left Band) [L HT6]	27	• Set the SSG as; Frequency : 449.980 MHz		
		(Right Band) [R HT6]	28			
	450.020 MHz	(Left Band) [L LT7]	29	• Set the SSG as; Frequency : 450.020 MHz		
		(Right Band) [R LT7]	30			
	500.020 MHz	(Left Band) [L MT7]	31	• Set the SSG as; Frequency : 500.020 MHz		
		(Right Band) [R MT7]	32			
	549.980 MHz	(Left Band) [L HT7]	33	• Set the SSG as; Frequency : 549.980 MHz		
		(Right Band) [R HT7]	34			

■ S-METER ADJUSTMENT

ADJUSTMENT ITEM		ADJUSTMENT CONDITIONS		OPERATION	VALUE	
S-METER	Connect a Standard Signal Generator to the antenna connector (J1).					
	127.020 MHz (S3 level)	(Left Band) [L S31]	1	<ul style="list-style-type: none"> Set the SSG as; Frequency : 127.020 MHz Level : -1 dBμ 	Push the right band's [MAIN•BAND] key.	(Automatic adjustment)
		(Right Band) [R S31]	2			
	(Full scale)	(Left Band) [L SF1]	3	<ul style="list-style-type: none"> Set the SSG as; Level : +15 dBμ 		
		(Right Band) [R SF1]	4			
	146.020 MHz (S3 level)	(Left Band) [L S32]	5	<ul style="list-style-type: none"> Set the SSG as; Frequency : 146.020 MHz Level : -1 dBμ 		
		(Right Band) [R S32]	6			
	(Full scale)	(Left Band) [L SF2]	7	<ul style="list-style-type: none"> Set the SSG as; Level : +15 dBμ 		
		(Right Band) [R SF2]	8			
	220.020 MHz (S3 level)	(Left Band) [L S33]	9	<ul style="list-style-type: none"> Set the SSG as; Frequency : 220.020 MHz Level : -1 dBμ 		
		(Full scale)	(Left Band) [L SF3]			
	300.020 MHz (S3 level)	(Left Band) [L S34]	11	<ul style="list-style-type: none"> Set the SSG as; Frequency : 300.020 MHz Level : -1 dBμ 		
		(Full scale)	(Left Band) [L SF4]			
	387.020 MHz (S3 level)	(Left Band) [L S35]	13	<ul style="list-style-type: none"> Set the SSG as; Frequency : 387.020 MHz Level : -1 dBμ 		
		(Right Band) [R S35]	14			
	(Full scale)	(Left Band) [L SF5]	15	<ul style="list-style-type: none"> Set the SSG as; Level : +15 dBμ 		
		(Right Band) [R SF5]	16			
	435.020 MHz (S3 level)	(Left Band) [L S36]	17	<ul style="list-style-type: none"> Set the SSG as; Frequency : 435.020 MHz Level : -1 dBμ 		
		(Right Band) [R S36]	18			
	(Full scale)	(Left Band) [L SF6]	19	<ul style="list-style-type: none"> Set the SSG as; Level : +15 dBμ 		
		(Right Band) [R SF6]	20			
	500.020 MHz (S3 level)	(Left Band) [L S37]	21	<ul style="list-style-type: none"> Set the SSG as; Frequency : 500.020 MHz Level : -1 dBμ 		
		(Right Band) [R S37]	22			
	(Full scale)	(Left Band) [L SF7]	23	<ul style="list-style-type: none"> Set the SSG as; Level : +15 dBμ 		
		(Right Band) [R SF7]	24			
	910.020 MHz (S3 level)	(Left Band) [R S38]	25	<ul style="list-style-type: none"> Set the SSG as; Frequency : 910.020 MHz Level : -1 dBμ 		
(Full scale)		(Right Band) [R SF8]	26			

■ SQUELCH ADJUSTMENT

• CONNECTION FOR SQUELCH ADJUSTMENT

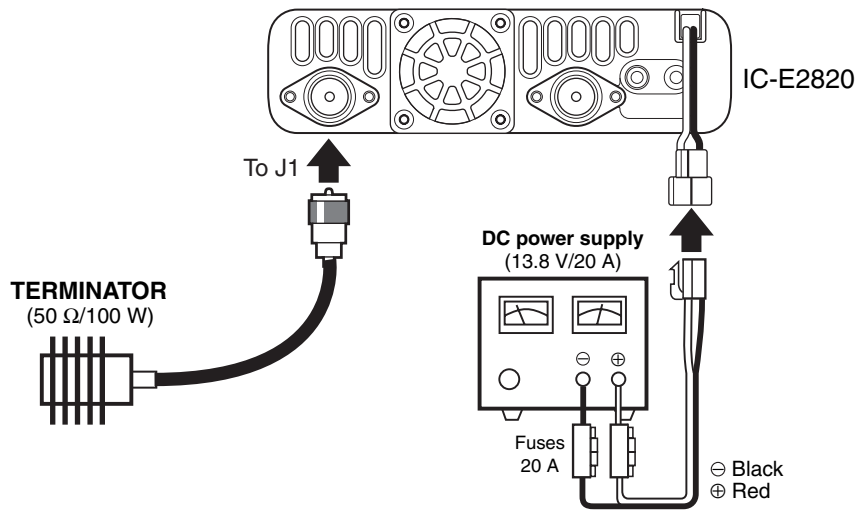

ADJUSTMENT ITEM		OPERATION		VALUE	
SQUELCH	Connect a Terminator (50 Ω) to the antenna connector (J1).				
	127.020 MHz	(FM) [L SQ1]	1	Push the right band's [MAIN•BAND] key.	(Automatic adjustment)
		(FM) [R SQ1]	2		
		(FM-N) [L SQ1]	3		
		(FM-N) [R SQ1]	4		
	146.020 MHz	(FM) [L SQ2]	5		
		(FM) [R SQ2]	6		
		(FM-N) [L SQ2]	7		
		(FM-N) [R SQ2]	8		
	220.020 MHz	(FM) [L SQ3]	9		
		(FM-N) [L SQ3]	10		
	300.020 MHz	(FM) [L SQ4]	11		
		(FM-N) [L SQ4]	12		
	387.020 MHz	(FM) [L SQ5]	13		
		(FM) [R SQ5]	14		
		(FM-N) [L SQ5]	15		
		(FM-N) [R SQ5]	16		
	440.020 MHz	(FM) [L SQ6]	17		
		(FM) [R SQ6]	18		
		(FM-N) [L SQ6]	19		
(FM-N) [R SQ6]		20			

■ SQUELCH ADJUSTMENT (continued)

ADJUSTMENT ITEM				OPERATION	VALUE
SQUELCH	500.020 MHz	(FM) [L SQ7]	21	Push the [MAIN•BAND] key.	(Automatic adjustment)
		(FM) [R SQ7]	22		
		(FM-N) [L SQ7]	23		
		(FM-N) [R SQ7]	24		
	910.020 MHz	(FM) [R SQ8]	25		
		(FM-N) [R SQ8]	26		

■ DIVERSITY ADJUSTMENT

• CONNECTION FOR DIVERSITY ADJUSTMENT

STANDARD SIGNAL GENERATOR (1)
(0.1–1 GHz)

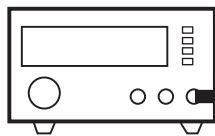

STANDARD SIGNAL GENERATOR (2)
(0.1–1 GHz)

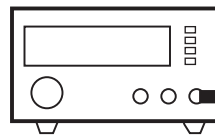

DC power supply
(13.8 V/20 A)

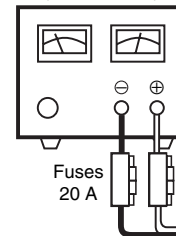

Fuses
20 A

⊖ Black
⊕ Red

ADJUSTMENT ITEM				ADJUSTMENT CONDITIONS	OPERATION	VALUE
DIVERSITY	Connect a Standard Signal Generator to each antenna connector (J1 and J2) independently.					
	127.020 MHz (S0 level)	(Left Band) [L DL1]	1	Set the SSG as; Frequency : 127.020 MHz Level : -6 dBμ	Push the right band's [MAIN•BAND] key.	(Automatic adjustment)
		(Right Band) [R DL1]	2			
	(S3 level)	(Left Band) [L DM1]	3	Set the SSG as; Level : -1 dBμ		
		(Right Band) [R DM1]	4			
	(Full scale)	(Left Band) [L DH1]	5	Set the SSG as; Level : +15 dBμ		
(Right Band) [R DH1]		6				

■ DIVERSITY ADJUSTMENT (continued)

ADJUSTMENT ITEM				ADJUSTMENT CONDITIONS	OPERATION	VALUE
DIVERSITY	145.020 MHz (S0 level)	(Left Band) [L DL2]	1	• Set the SSG as; Frequency : 145.020 MHz Level : -6 dBμ	Push the right band's [MAIN• BAND] key.	(Automatic adjustment)
		(Right Band) [R DL2]	2			
	(S3 level)	(Left Band) [L DM2]	3	• Set the SSG as; Level : -1 dBμ		
		(Right Band) [R DM2]	4			
	(Full scale)	(Left Band) [L DH2]	5	• Set the SSG as; Level : +15 dBμ		
		(Right Band) [R DH2]	6			
	387.020 MHz (S0 level)	(Left Band) [L DL5]	1	• Set the SSG as; Frequency : 387.020 MHz Level : -6 dBμ		
		(Right Band) [R DL5]	2			
	(S3 level)	(Left Band) [L DM5]	3	• Set the SSG as; Level : -1 dBμ		
		(Right Band) [R DM5]	4			
	(Full scale)	(Left Band) [L DH5]	5	• Set the SSG as; Level : +15 dBμ		
		(Right Band) [R DH5]	6			
	435.020 MHz (S0 level)	(Left Band) [L DL6]	1	• Set the SSG as; Frequency : 435.020 MHz Level : -6 dBμ		
		(Right Band) [R DL6]	2			
	(S3 level)	(Left Band) [L DM6]	3	• Set the SSG as; Level : -1 dBμ		
		(Right Band) [R DM6]	4			
	(Full scale)	(Left Band) [L DH6]	5	• Set the SSG as; Level : +15 dBμ		
		(Right Band) [R DH6]	6			
	500.020 MHz (S0 level)	(Left Band) [L DL7]	1	• Set the SSG as; Frequency : 500.020 MHz Level : -6 dBμ		
		(Right Band) [R DL7]	2			
	(S3 level)	(Left Band) [L DM7]	3	• Set the SSG as; Level : -1 dBμ		
		(Right Band) [R DM7]	4			
	(Full scale)	(Left Band) [L DH7]	5	• Set the SSG as; Level : +15 dBμ		
		(Right Band) [R DH7]	6			

[MAIN UNIT]

Table with columns: REF NO., ORDER NO., DESCRIPTION, M., H/V LOCATION. Rows include items C105 through C214 with various descriptions and locations.

[MAIN UNIT]

Table with columns: REF NO., ORDER NO., DESCRIPTION, M., H/V LOCATION. Rows include items C215 through C325 with various descriptions and locations.

M.=Mounted side (T: Mounted on the Top side, B: Mounted on the Bottom side) S.=Surface mount

[MAIN UNIT]

REF NO.	ORDER NO.	DESCRIPTION	M.	H/V LOCATION
EP48	6910018460	S.BEA MMZ1005Y102C-T	T	91/61.3
EP49	6910014690	S.BEA MPZ1608S221A-T	T	121.3/152.3
EP50	6910014690	S.BEA MPZ1608S221A-T	T	109.4/155.1
EP51	6910018460	S.BEA MMZ1005Y102C-T	T	119.3/144.2
EP52	6910014690	S.BEA MPZ1608S221A-T	T	128.6/143.6
EP53	6910014690	S.BEA MPZ1608S221A-T	T	126.3/144.3
EP54	6910014690	S.BEA MPZ1608S221A-T	T	113.9/138.9
EP55	6910014690	S.BEA MPZ1608S221A-T	T	108.6/147.8
EP56	6910018460	S.BEA MMZ1005Y102C-T	B	119.3/38.5
EP57	6910018460	S.BEA MMZ1005Y102C-T	B	119.3/37.6
EP58	6910018460	S.BEA MMZ1005Y102C-T	B	119.3/36.7
EP59	6910014690	S.BEA MPZ1608S221A-T	B	117.2/36.3
EP60	6910014690	S.BEA MPZ1608S221A-T	B	117.2/35.1
EP61	6910018460	S.BEA MMZ1005Y102C-T	B	119.3/34.3
EP62	6910018460	S.BEA MMZ1005Y102C-T	B	119.3/33.4
EP63	6910018460	S.BEA MMZ1005Y102C-T	B	119.3/32.5
EP64	6910018460	S.BEA MMZ1005Y102C-T	B	119.3/31.6
EP66	6910018460	S.BEA MMZ1005Y102C-T	B	127.7/35
EP68	6910018460	S.BEA MMZ1005Y102C-T	B	41.6/14.3
EP69	6910018460	S.BEA MMZ1005Y102C-T	T	52.6/10.4
EP70	6910018460	S.BEA MMZ1005Y102C-T	T	45/8
EP71	6910012350	S.BEA MMZ1608Y 102BT	T	47.5/130.7

[VR1 UNIT]

REF NO.	ORDER NO.	DESCRIPTION	M.	H/V LOCATION
R1	7210003250	VAR RV-320 (RK097221005H)		
W1	8900016030	CBL OPC-1666 <TJM>		

[VR2 UNIT]

REF NO.	ORDER NO.	DESCRIPTION	M.	H/V LOCATION
R1	7210003250	VAR RV-320 (RK097221005H)		
W1	8900016030	CBL OPC-1666 <TJM>		

M.=Mounted side (T: Mounted on the Top side, B: Mounted on the Bottom side)
S.=Surface mount

SECTION 7

MECHANICAL PARTS

[CHASSIS PARTS]

REF NO.	ORDER NO.	DESCRIPTION	QTY.
J1	6510004880	MR-DSE-01	1
J2	6510004880	MR-DSE-01	1
P1	6510009580	ZHR-2	1
SP1	2510001160	057P0802	1
MF1	2710000820	EFB0412VHD-6P38	1
W1	9016420020	23/04/140/B09/W01	1
W2	9016420010	23/00/140/B09/W01	1
MP1	8010020640	2969 CHASSIS	1
MP2	8210023550	2969 CHASSIS PANEL	1
MP3	8310068650	2969 MAGNET PLATE	1
MP5	8110009000	2969 U-COVER	1
MP6	8110009010	2969 L-COVER	1
MP7	8110009020	2969 FAN COVER	1
MP8	8930071460	2969 SP SPONGE	1
MP9	8930071380	2969 IC CLIP	1
MP10	8810009611	Screw M2.6X6 ZK3	17
MP12	8810008661	Screw BT B0 3X8 NI-ZC3 (BT)	11
MP13	8810008661	Screw BT B0 3X8 NI-ZC3 (BT)	4
MP14	8810008661	Screw BT B0 3X8 NI-ZC3 (BT)	4
MP15	8810009991	Screw BT B0 3X8 NI-ZK3 (BT)	5
MP16	8810010141	Screw PH M3X30 ZK3	4
MP18	8930014980	59 saran net	1
MP19	8930072260	2969 NET	1
MP20	8930071590	THERMALLY SHEET (BI)	1
MP36	8930016800	Thermal sheet (U)	1
MP38	8930041160	Sheet (BO)	1
MP39	8930018810	Sheet (AA)	1

[CONTROL UNIT]

REF NO.	ORDER NO.	DESCRIPTION	QTY.
J5	6510025730	HJC0187-010024	1
DS1	5030003040	M6-0103TRM-5	1
S15	2250000570	SW-169	1
S16	2250000570	SW-169	1
MP1	8210023490	2969 FRONT PANEL (Inc. MP19)	1
MP2	8210023500	2969 REAR PANEL (Inc. MP25)	1
MP3	8310068770	2969 WINDOW PLATE(A)	1
MP4	8310068550	2969 WINDOW LINE	1
MP5	8310068560	2969 SUB RING	2
MP6	8310068570	2969 MAIN RING	2
MP7	8610013060	KNOB K-263	1
MP8	8610013070	KNOB K-263 (A)	1
MP9	8610013030	KNOB N-353	2
MP10	8610013040	KNOB N-354	2
MP11	8610013050	KNOB N-355	2
MP12	8310068600	2969 KNOB PLATE	2
MP13	8610011310	KNOB K-229	2
MP14	8610013100	KNOB K-229 (J)	2
MP15	8610013080	KNOB K-229 (K)	1
MP16	8610013090	KNOB K-229 (L)	1
MP17	8610013110	KNOB K-229 (M)	1
MP18	8210023540	2969 REFLECTOR	1
MP19	8930071250	2969 WINDOW SHEET	1
MP20	8930071430	2969 KEY SPONGE	1
MP21	8930071410	2969 KEY SHEET	1
MP23	8930006440	Push spring (F)	2
MP25	8830003020	Bit insert SB-264540-CD	2
MP26	8610007510	Knob spring NO.7800	2
MP27	8610007420	Knob spring NO.6601	2
MP28	8830001010	HEX NUT (A)	2
MP29	8810009221	Screw BT B0 2X8 NI-ZK3 (BT)	8
MP40	8930071860	2969 LCD PLATE	1
MP41	8930072030	2969 LCD FILTER	1
MP42	8930072020	2969 LCD SHEET	1
MP44	8930072050	2969 RBEF SHEET	1

[VR1 UNIT]

REF NO.	ORDER NO.	DESCRIPTION	QTY.
R1	7210003250	RV-320	1
W1	8900016030	OPC-1666	1

[VR2 UNIT]

REF NO.	ORDER NO.	DESCRIPTION	QTY.
R1	7210003250	RV-320	1
W1	8900016030	OPC-1666	1

[MAIN UNIT]

REF NO.	ORDER NO.	DESCRIPTION	QTY.
J2	6510023110	3008L-8P8C	1
J3	6510025950	PCB-606 (6P6C)	1
J4	6510023161	DN-508B-6-L	1
J5	6450001430	HSJ1462-01-010	1
J8	6510025940	PJ-3047S	1
J9	6450001440	HSJ1403-01-010	1
W1	8900016070	OPC-1669	1
W2	8900016070	OPC-1669	1
W5	7120000470	ERDS2T0	1
W6	7120000470	ERDS2T0	1
W7	8900016020	OPC-1671	1
MP2*	8510018150	2969 B-VCO CASE	1
MP3*	8510014940	2601 VCO CASE	1
MP4*	8510018150	2969 B-VCO CASE	1
MP5*	8510014940	2601 VCO CASE	1
MP6*	8510016470	2775 VCO CASE	1
MP7*	8510016470	2775 VCO CASE	1
MP8*	8510018140	2969 S-VCO CASE	1
MP9*	8510018140	2969 S-VCO CASE	1
MP10	8510018160	2969 B-VCO COVER	2
MP11	8510014950	2601 VCO COVER	2
MP12	8510016460	2775 VCO COVER	2
MP13	8510016460	2775 VCO COVER	2
MP14	8930060270	2633 M-SHEET	2
MP15	8930059770	2633 M-HOLDER	2
MP16	8930073170	SPONGE(JQ)	1
MP17	8930073180	SPONGE(JR)	1

*: Refer to SECTION 8 BOARD LAYOUTS.

[ACCESSORIES]

REF NO.	ORDER NO.	DESCRIPTION	QTY.
MC1	Option	HM-133	1
F1	5210000080	FGB 20A	1
W1	Option	OPC-1132	1
W2	8900016370	OPC-1712	1
W3	8900016050	OPC-1663	1
MP1	8010016730	150 MOBIL BRACKET (SI)	1
MP2	8930041170	452 FELT (SI)	2
MP3	8820000530	Flange bolt M4X8 NI	4
MP4	8810000951	Screw BT A0 5X16 ZC3	4
MP5	8850000180	Flat washer M5 SUS	4
MP6	8850000500	S-washer M5 SUS	4
MP7	8810000471	Screw PH (+) M5X12 ZC3	4
MP8	8830000250	Nut M5 SUS	4
MP9	8930007300	MIC hanger	1
MP20	8310068640	2969 CHASSIS PLATE	1
MP21	8810009611	Screw M2.6X6 ZK3	1
MP22	8010020830	2969 BRACKET (Inc. MP2)	1
MP25	6910018710	NDRDY-15060304	2
MP26	8810009611	Screw M2.6X6 ZK3	2

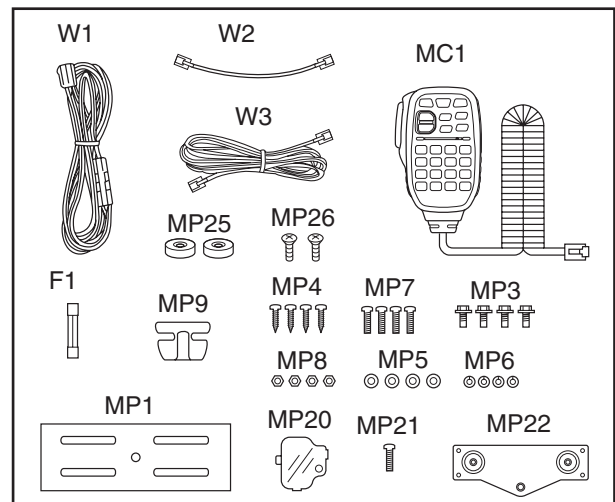

Screw abbreviations

A, B0, BT: Self-tapping PH: Pan head ZK: Black NI-ZU: Nickel-Zinc SUS: Stainless

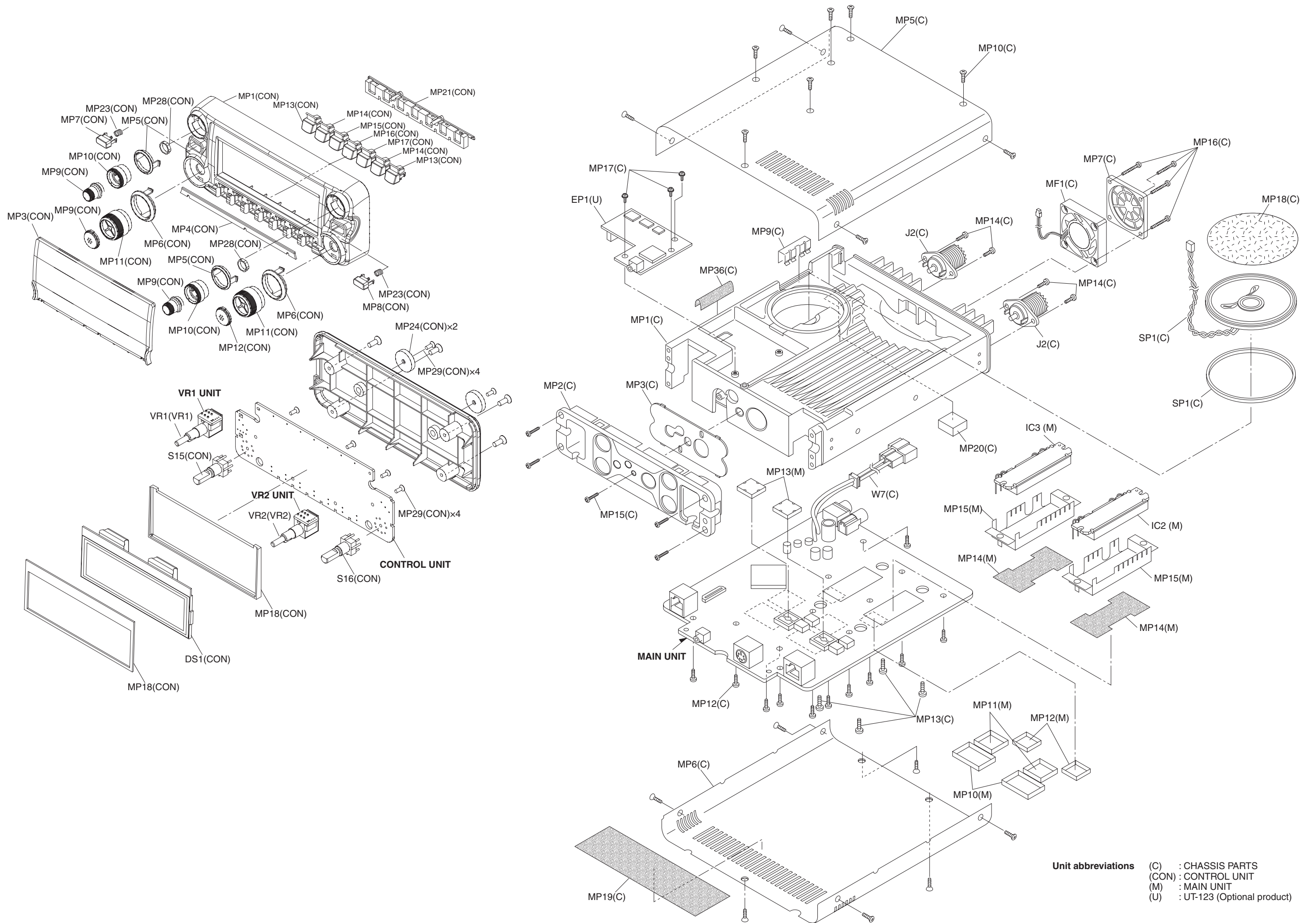

Unit abbreviations
 (C) : CHASSIS PARTS
 (CON) : CONTROL UNIT
 (M) : MAIN UNIT
 (U) : UT-123 (Optional product)

SECTION 8

BOARD LAYOUTS

• MAIN UNIT (TOP VIEW)

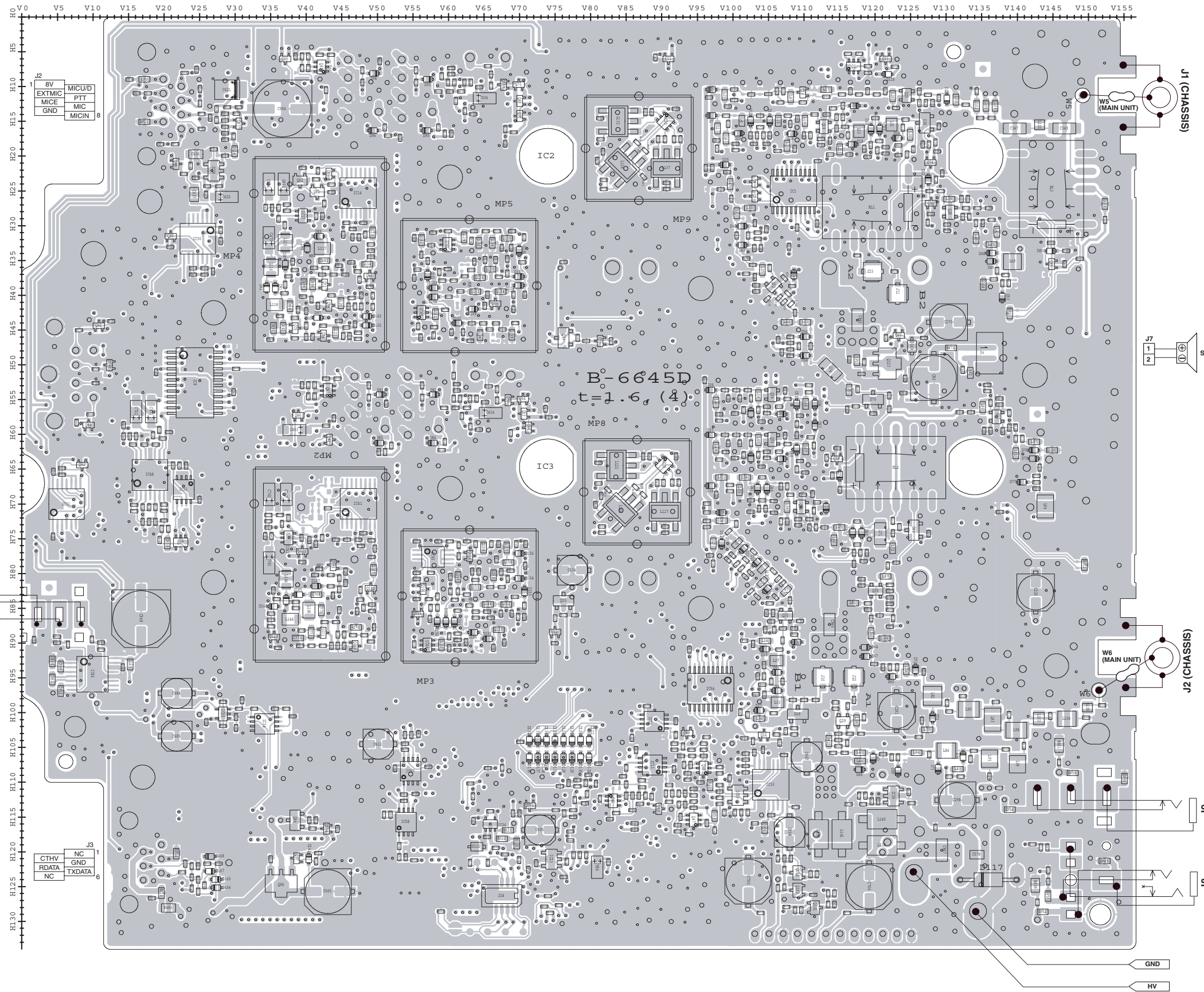

• HM-133 (TOP VIEW)

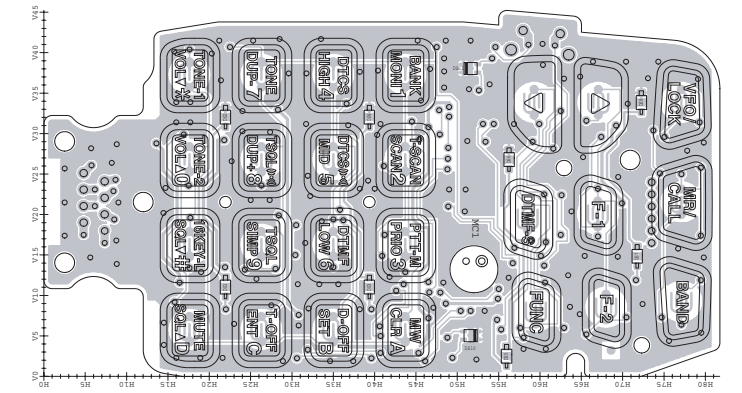

• VR1 UNIT (TOP VIEW)

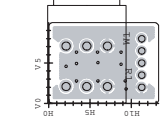

• CONTROL UNIT (TOP VIEW)

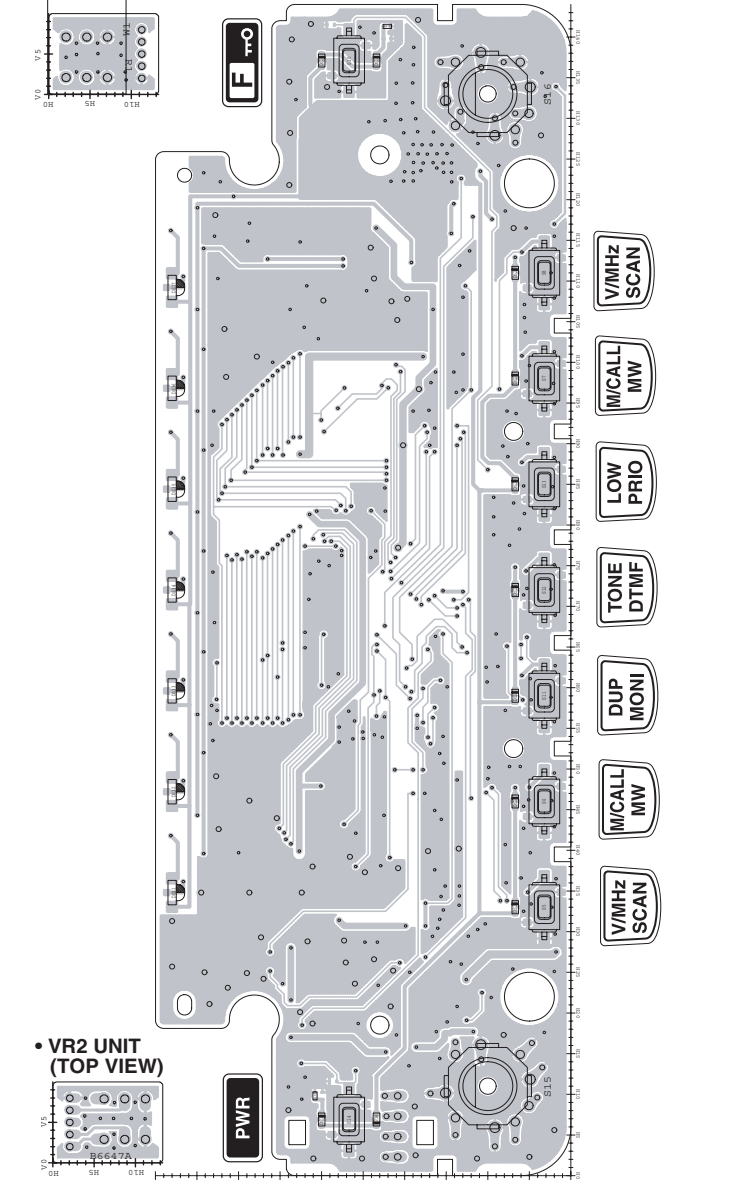

The combination of this side and the bottom side shows the board layout in the same configuration as the actual P.C.Board.

• HM-133 (BOTTOM VIEW)

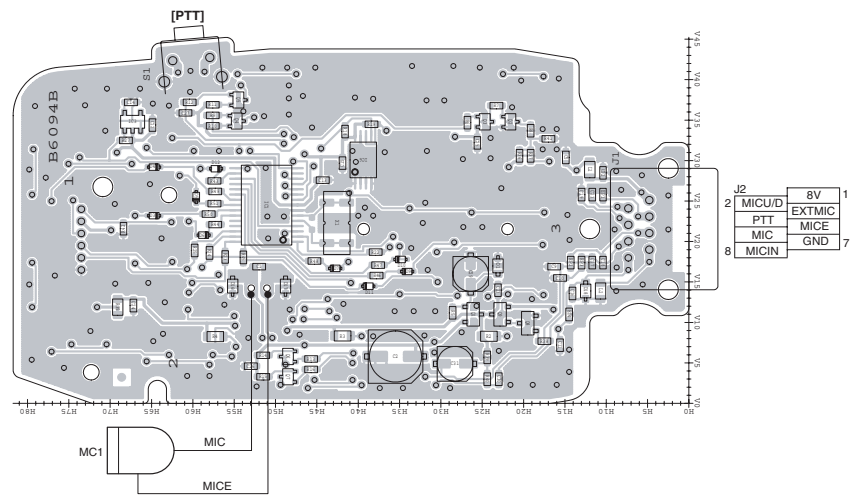

• MAIN UNIT (BOTTOM VIEW)

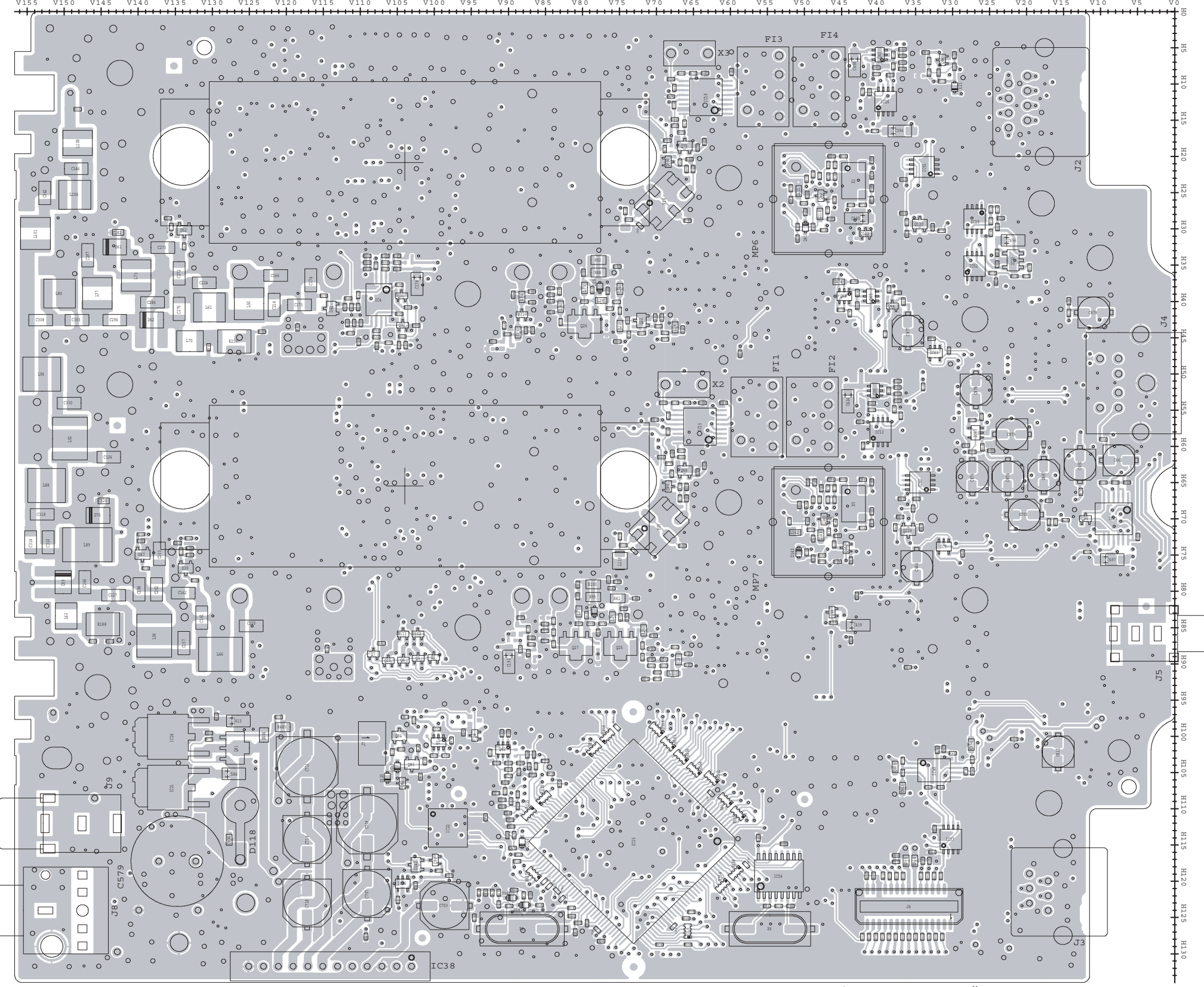

• CONTROL UNIT (BOTTOM VIEW)

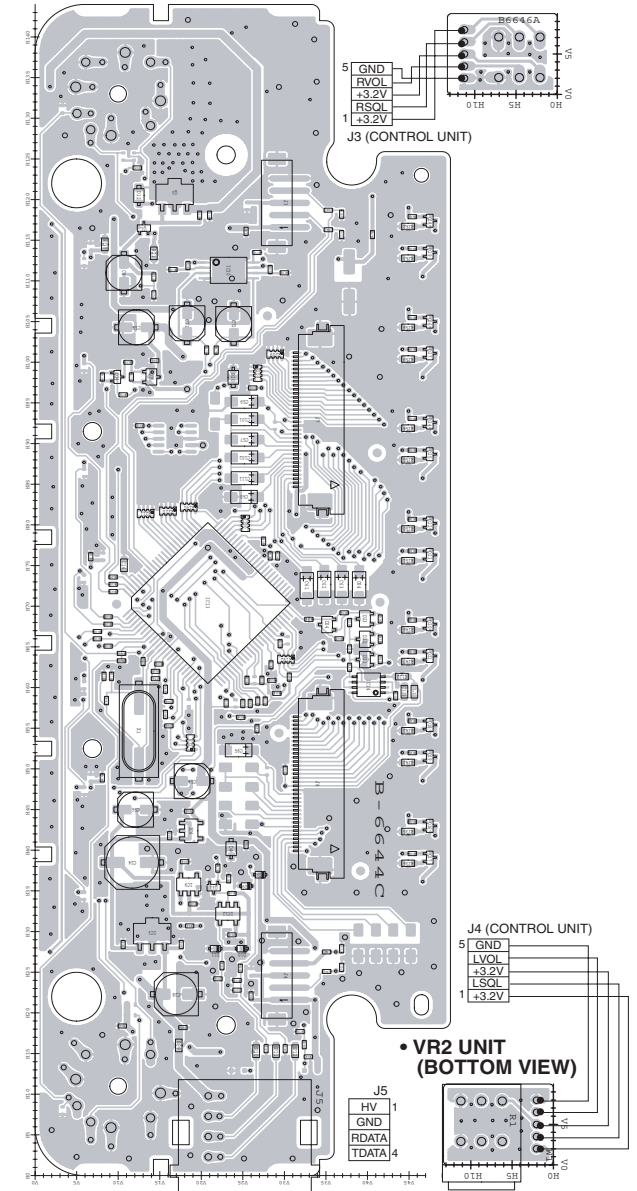

• VR1 UNIT (BOTTOM VIEW)

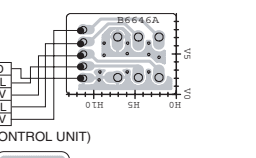

• VR2 UNIT (BOTTOM VIEW)

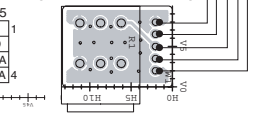

30	GND	NC
29	NC	NC
28	BTONE	AMBERTX
27	DMFOUT	AMBERTX
26	AF	DVC
25	DMOD	AOO
24	OSV	TKXK
23	OP-RV	TKXK
22	AMBERTN	TKXK
21	AMBERTS	DCR
20	AMBERTS	DCR
19	AMBERTK	CRUSV
18	GND	GPSOPT
17	GPSMOD	GPSREBT
16	GPSMOD	GPSREBT
15		

SECTION 9

BLOCK DIAGRAM

• BLOCK DIAGRAM (Left side)

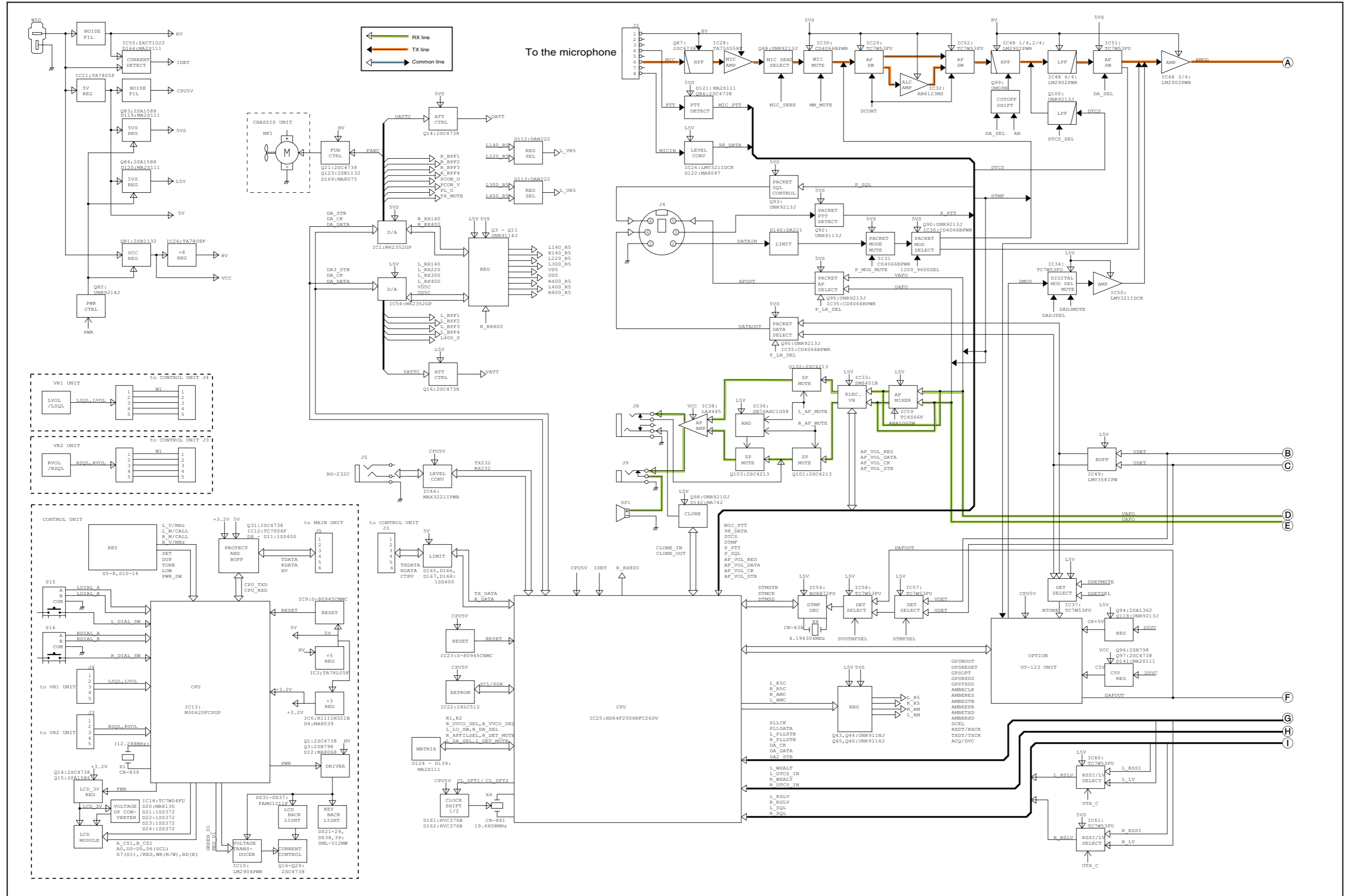

• BLOCK DIAGRAM (Right side)

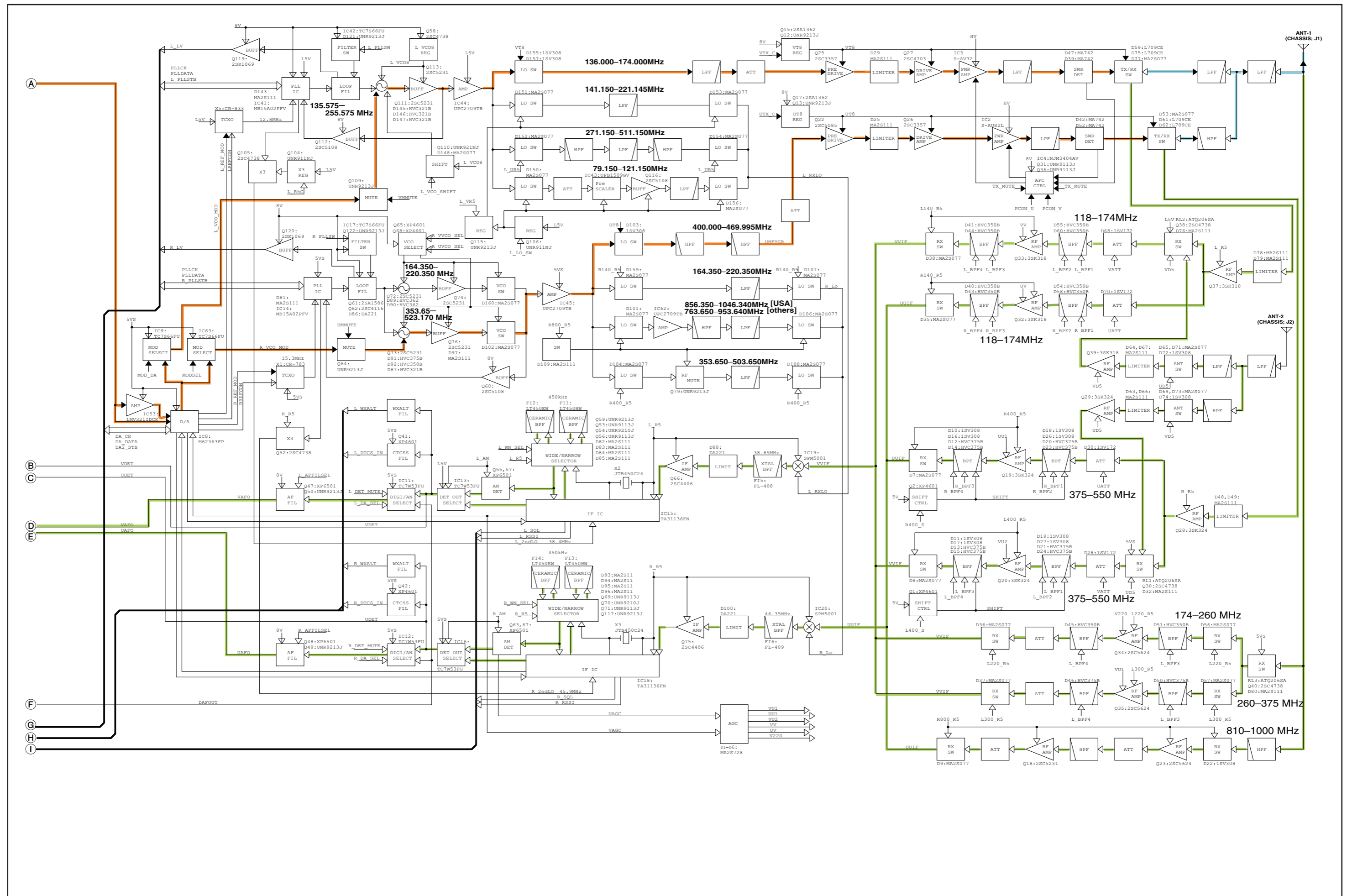

SECTION 10

VOLTAGE DIAGRAM

10-1 CONTROL UNIT

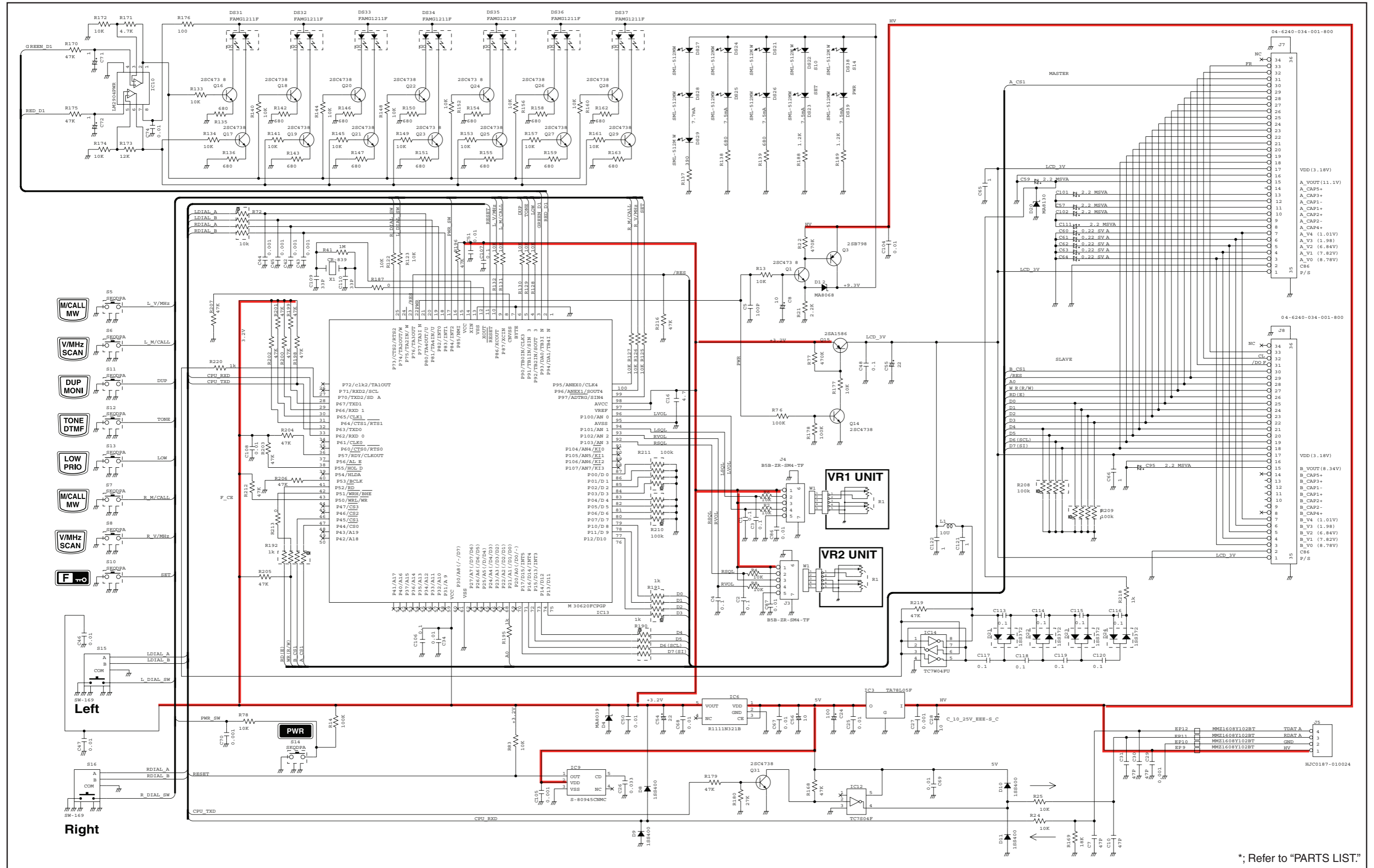

*; Refer to "PARTS LIST"

10-2 MAIN UNIT (1)

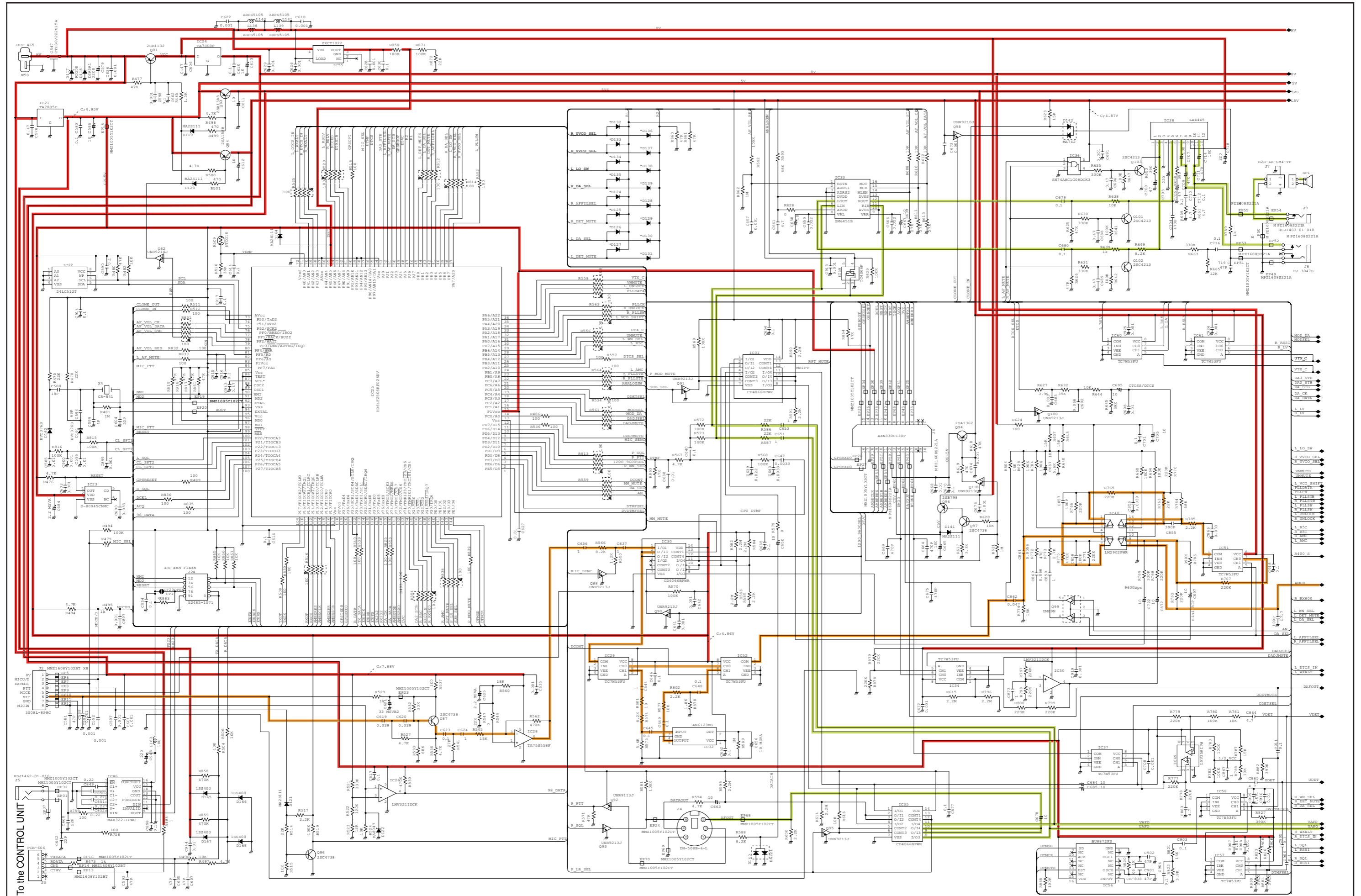

To the CONTROL UNIT

*; Refer to "PARTS LIST"

MAIN UNIT (2)

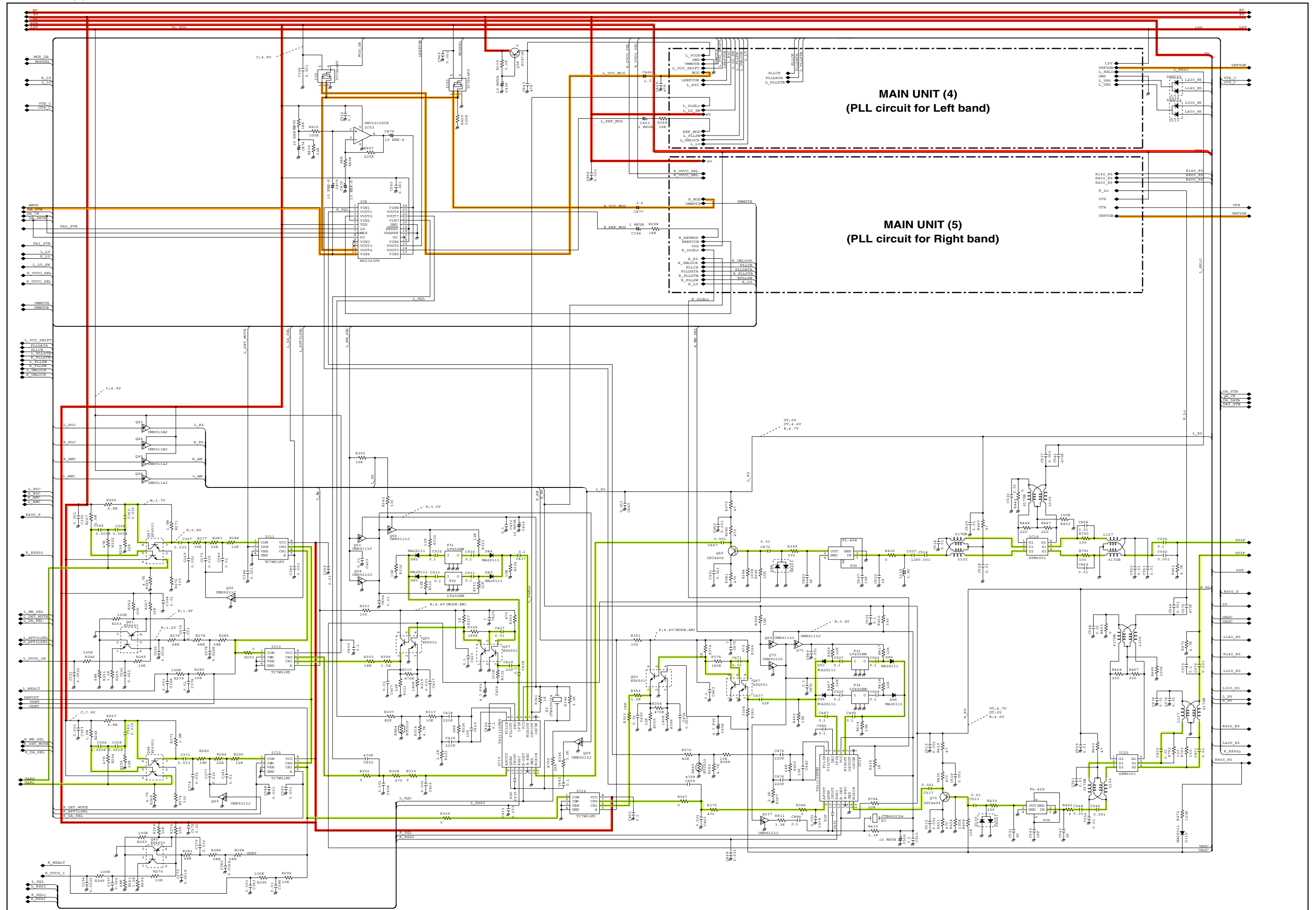

MAIN UNIT (4)
(PLL circuit for Left band)

MAIN UNIT (5)
(PLL circuit for Right band)

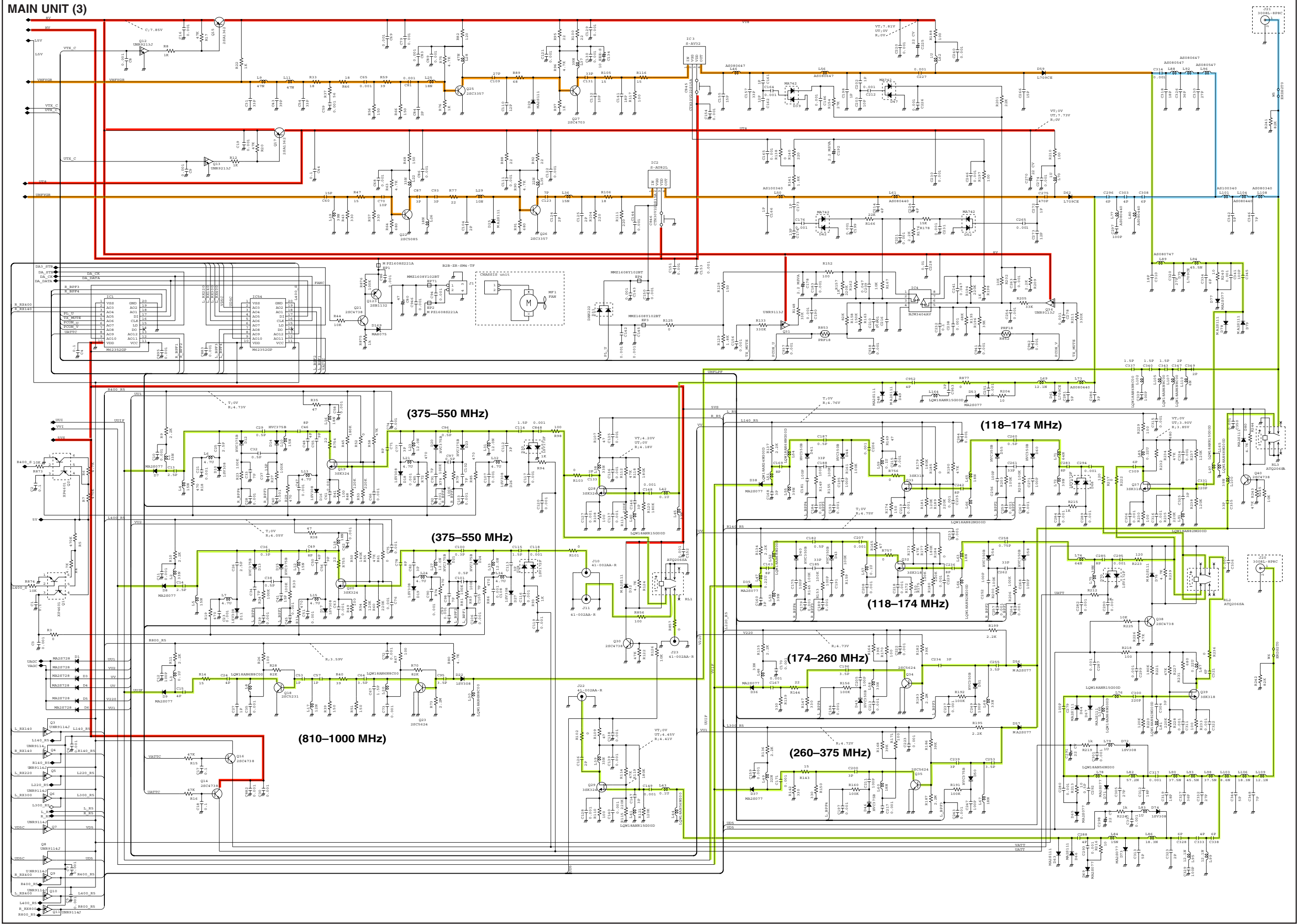

MAIN UNIT (4)

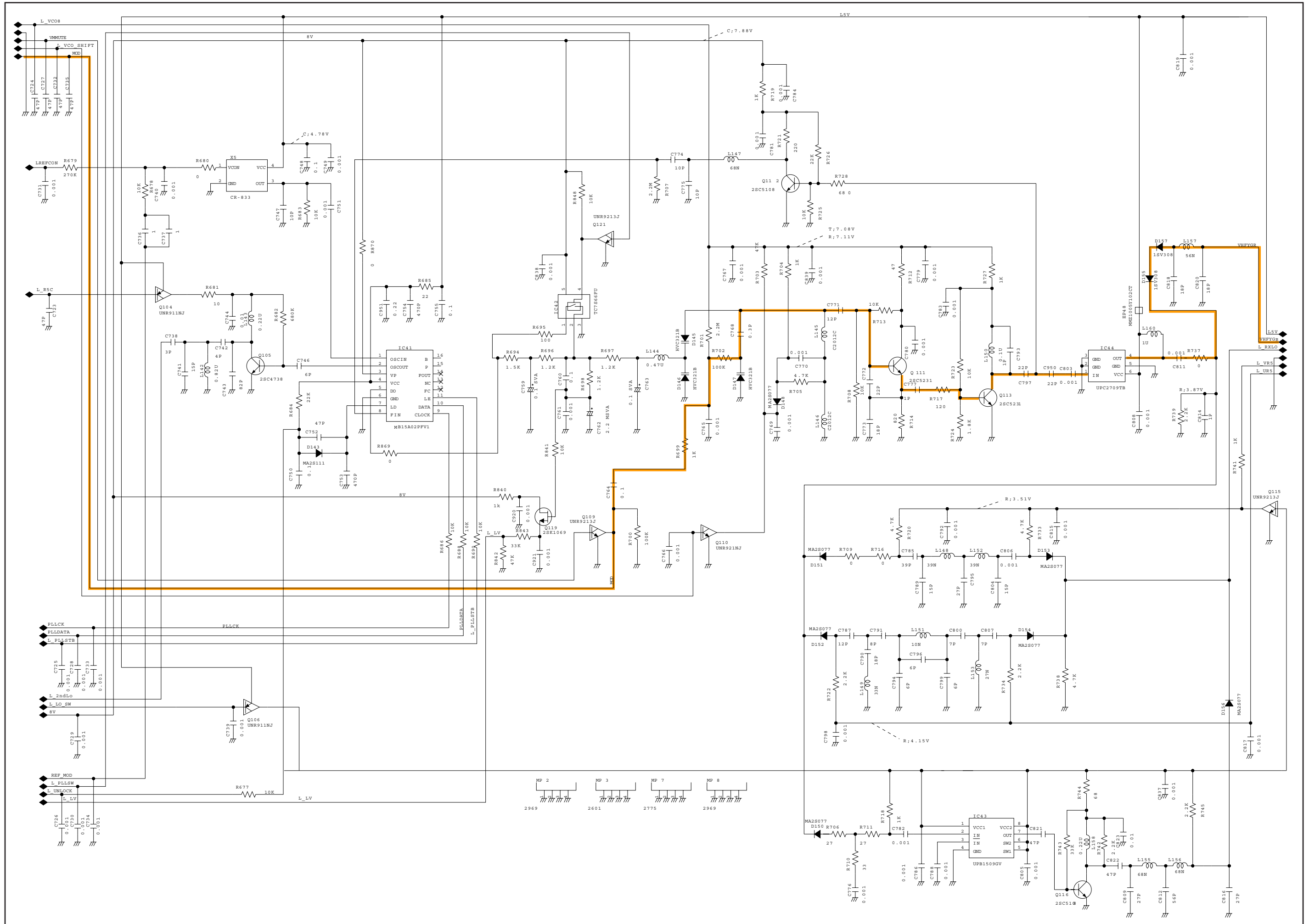

MAIN UNIT (5)

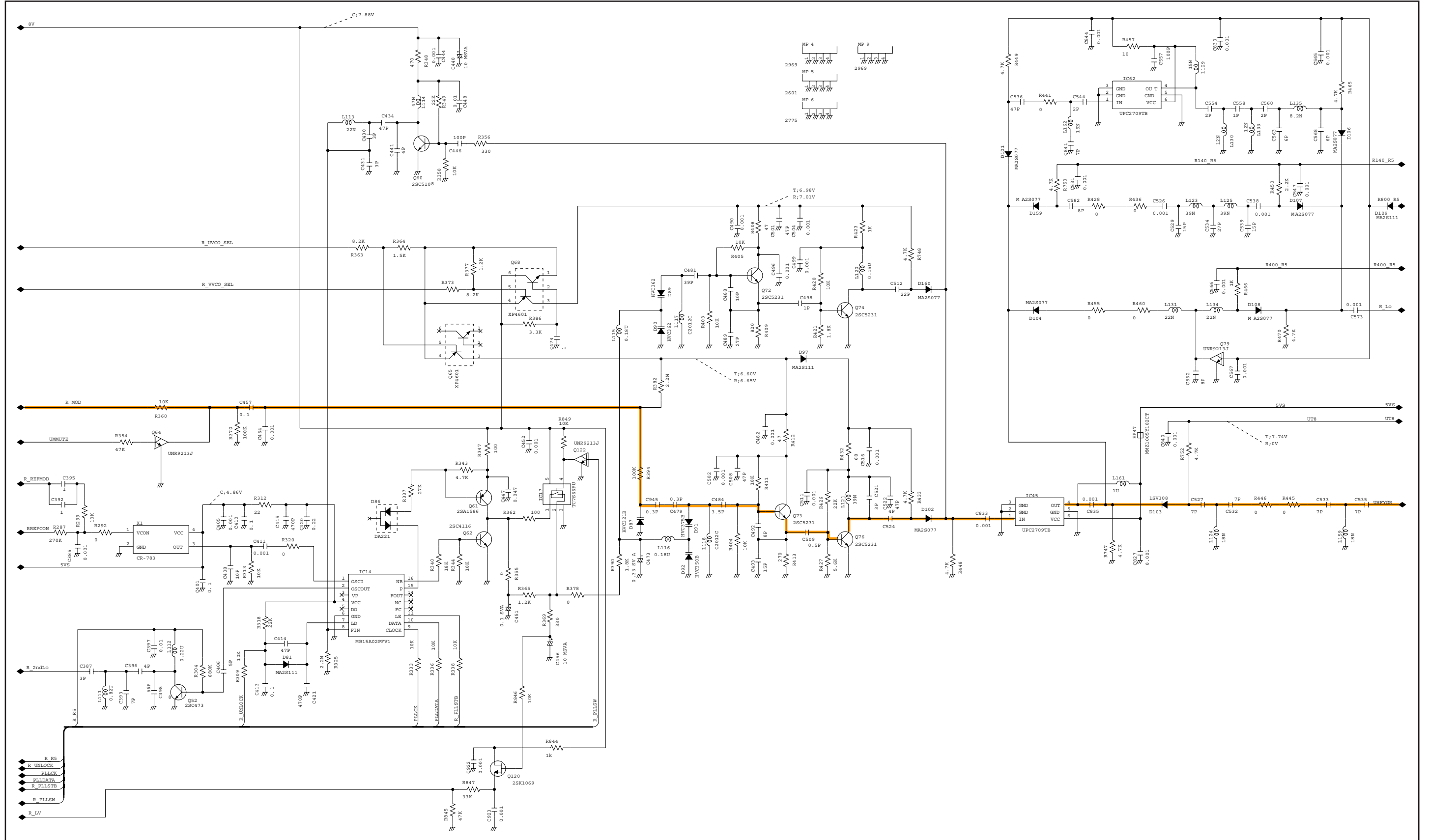

• BOARD LAYOUTS

• MAIN UNIT (TOP VIEW)

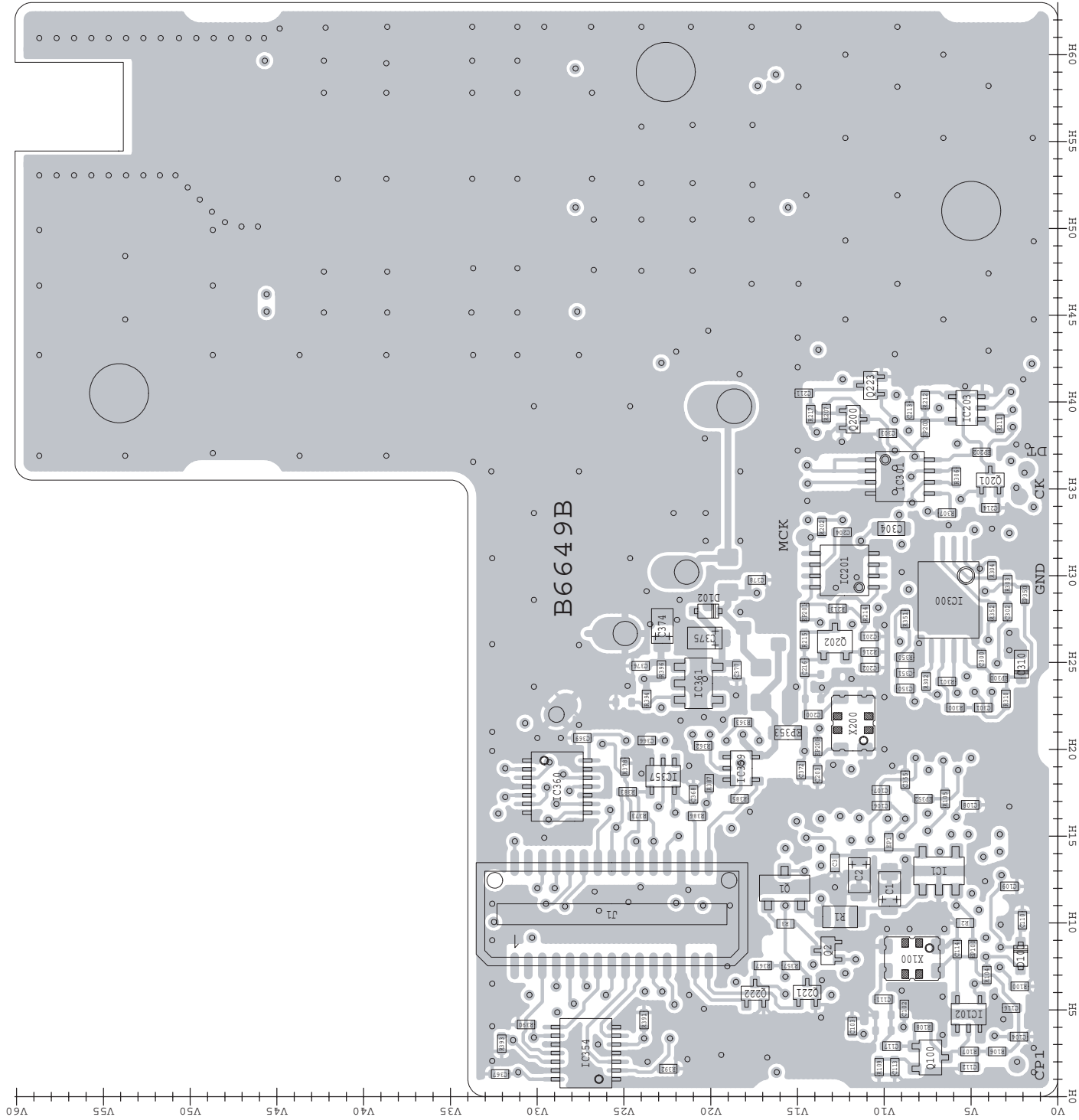

• MAIN UNIT (BOTTOM VIEW)

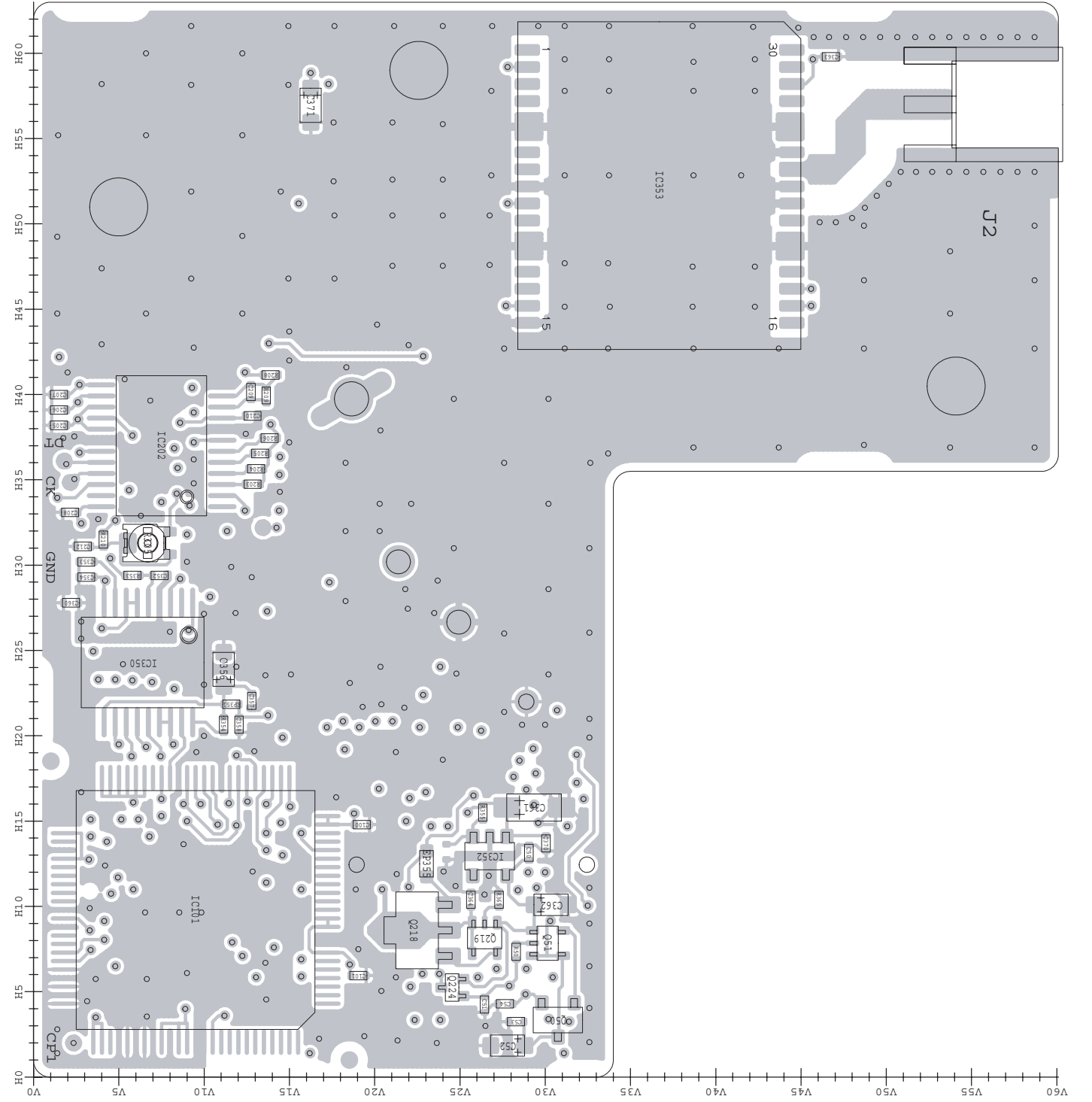

Icom Inc.

1-1-32, Kamiminami, Hirano-ku, Osaka 547-0003, Japan
Phone : +81 (06) 6793 5302
Fax : +81 (06) 6793 0013
URL : <http://www.icom.co.jp/world/index.html>

Icom America Inc.

<Corporate Headquarters>
2380 116th Avenue N.E., Bellevue, WA 98004, U.S.A.
Phone : +1 (425) 454-8155 Fax : +1 (425) 454-1509
URL : <http://www.icomamerica.com>
E-mail : sales@icomamerica.com
<Customer Service>
Phone : +1 (425) 454-7619

Icom Canada

Glenwood Centre #150-6165
Highway 17 Delta, B.C., V4K 5B8, Canada
Phone : +1 (604) 952-4266 Fax : +1 (604) 952-0090
URL : <http://www.icomcanada.com>
E-mail : info@icomcanada.com

Icom (Australia) Pty. Ltd.

Unit 1 / 103 Garden Road, Clayton VIC 3168 Australia
Phone : +61 (03) 9549-7500 Fax : +61 (03) 9549-7505
URL : <http://www.icom.net.au>
E-mail : sales@icom.net.au

Icom New Zealand

146A Harris Road, East Tamaki,
Auckland, New Zealand
Phone : +64 (09) 274 4062 Fax : +64 (09) 274 4708
URL : <http://www.icom.co.nz>
E-mail : inquiries@icom.co.nz

Beijing Icom Ltd.

10C01, Long silver Mansion, No.88, YongDing
Road, Haidian District, Beijing, 100039, China
Phone : +86 (010) 5889 5391/5392/5393
Fax : +86 (010) 5889 5395
E-mail : bjicom@bjicom.com
URL : <http://www.bjicom.com>

Icom (Europe) GmbH

Communication Equipment
Himmelgeister Str. 100, D-40225 Düsseldorf, Germany
Phone : +49 (0211) 346047 Fax : +49 (0211) 333639
URL : <http://www.icomeurope.com>
E-mail : info@icomeurope.com

Icom Spain S.L

Ctra. Rubi, 88, 08190, Sant Cugat del Valles, Barcelona, SPAIN
Phone : +34 (93) 590 26 70 Fax : +34 (93) 589 04 46
URL : <http://www.icomspain.com>
E-mail : icom@icomspain.com

Icom (UK) Ltd.

Unit 9, Sea St., Herne Bay, Kent, CT6 8LD, U.K.
Phone : +44 (01227) 741741 Fax : +44 (01227) 741742
URL : <http://www.icomuk.co.uk>
E-mail : info@icomuk.co.uk

Icom France s.a.s.

Zac de la Plaine
1 Rue Brindejonc des Moulinais BP 5804
31505 Toulouse Cedex, France
Phone : +33 (5) 61 36 03 03 Fax : +33 (5) 61 36 03 00
URL : <http://www.icom-france.com>
E-mail : icom@icom-france.com

Asia Icom Inc.

6F No.68, Sec. 1 Cheng-Teh Road, Taipei, Taiwan, R.O.C.
Phone : +886 (02) 2559 1899 Fax : +886 (02) 2559 1874
URL : <http://www.asia-icom.com>
E-mail : sales@asia-icom.com

Icom Polska

Sopot, 3 Maja 54 Poland
Phone : +48 (58) 550 7135 Fax : +48 (58) 551 0484
E-mail : icompolska@icompolska.com.pl

Count on us!

Icom Inc.

1-1-32, Kamiminami, Hirano-ku, Osaka 547-0003, Japan

S-14326XZ-C1
© 2007 Icom Inc.